

Service Manual

PW4NX

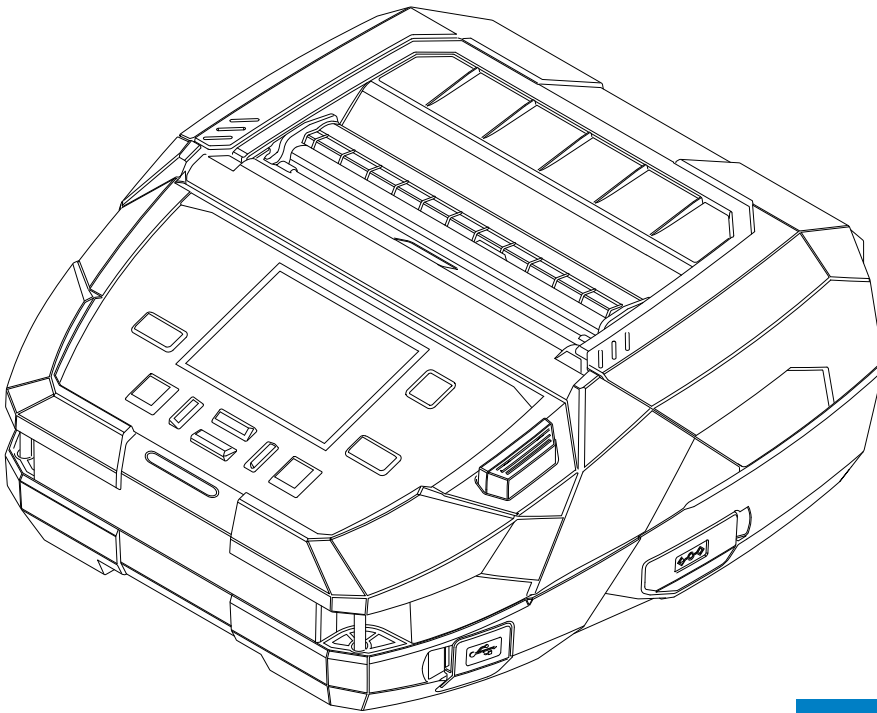

1 Introduction



**2 Operation
and
Configuration**



**3 Checking and
Performing
Printer Adjustments**



4 Replacement



5 Options



6 Troubleshooting

Copyrights

Any unauthorized reproduction of the contents of this document, in part or whole, is strictly prohibited.

Limitation of Liability

- SATO Corporation and its subsidiaries in Japan, the U.S. and other countries make no representations or warranties of any kind regarding this material, including, but not limited to, implied warranties of merchantability and fitness for a particular purpose. SATO Corporation shall not be held responsible for errors contained herein or any omissions from this material or for any damages, whether direct, indirect, incidental or consequential, in connection with the furnishing, distribution, performance or use of this material.
- Specifications and contents in this document are subject to change without notice.
- Be sure to perform a virus check on the USB memory before connecting it to the product. SATO Corporation shall not be held responsible for any product malfunctions caused by a virus spread via USB memory.

Trademarks

- SATO and Stylized SOS (SATO Online Services) are a registered trademark of SATO Holdings Corporation and its subsidiaries in Japan, the U.S. and other countries.
- NiceLabel[®] is a trademark or registered trademark of Euro Plus d.o.o.
- QR Code is a registered trademark of DENSO WAVE INCORPORATED.
- Wi-Fi[®] is a registered trademark of Wi-Fi Alliance.
- Wi-Fi Direct[™], Wi-Fi Protected Setup[™], WPA[™] and WPA2[™] are trademarks of Wi-Fi Alliance.
- Windows and Microsoft Edge are registered trademarks of Microsoft Corporation in the United States.
- Bluetooth is a trademark of Bluetooth SIG, Inc., U.S.A.
- Android, YouTube, the YouTube logo, and Google Chrome are trademarks of Google LLC.
- iPad, iPhone, iPod and iPod touch are registered trademarks of Apple Inc., registered in the U.S. and other countries.
- IOS (Internetwork Operating System) is a trademark or registered trademark of Cisco in the U.S. and other countries and is used under license.
- Atheros is a registered trademark of Qualcomm Atheros, Inc.
- All other trademarks are the property of their respective owners.

1	Introduction.....	4
1.1	About This Manual.....	4
1.2	Precautions	4
1.3	Parts Identification of the Printer	5
1.3.1	Front View	5
1.3.2	Rear View	5
1.3.3	Internal View	6
1.3.4	Operator Panel View	6
2	Operation and Configuration.....	7
2.1	About [Settings] menu	8
2.2	About [Tools] menu.....	9
2.2.1	Test Print.....	10
2.2.2	HEX-Dump.....	11
2.2.3	Reset.....	12
2.2.4	Install Certificates, Delete Certificates	13
2.2.5	Clone.....	14
2.2.6	Startup Guide.....	15
2.3	About [Service Mode].....	17
2.3.1	Logging in Service Menu	17
2.3.2	Details of the Service Menu	18
2.3.3	Maintenance	19
2.3.4	Factory Offset	20
2.3.5	Factory Pitch	21
2.4	Checking and Updating the Firmware	22
3	Checking and Performing Printer Adjustments	23
3.1	Checking Before Starting Work.....	25
3.1.1	Checking Printing with Actual User Data	25
3.1.2	Checking Installation Environment and Printer Conditions	25
3.1.3	Checking Printing with Factory Settings	26
3.1.4	Disabling the SOS Connection	28
3.1.5	Checking the Battery Status	28

3. 2	Checking and Cleaning	29
3.2.1	Checking and Cleaning the Print Head (Thermal Head).....	29
3.2.2	Checking and Cleaning the Platen Roller	29
3.2.3	Checking and Cleaning the Media Sensors.....	30
3. 3	Checks and Adjustments	31
3.3.1	Checking and Adjusting the I-mark Sensor and Gap Sensor	31
3.3.2	Printing Quality.....	35
3.3.3	Meandering	36
3.3.4	Checking and Adjusting the Print Position	36
3.3.5	Checking the Stop Position.....	36
3. 4	Final Check	37
3.4.1	Checking Test Print with Factory Settings	37
3.4.2	Checking the Customer's Layout	37
3.4.3	Checking Barcode Scan	37
3.4.4	Checking SOS Connection	38
3.4.5	Returning to the Original State.....	38
4	Replacement	39
4. 1	Notes on Replacing Parts	41
4. 2	EXPLODED VIEW	42
4. 3	Case Cover	43
4.3.1	Replacing the TOP COVER ASSY	43
4.3.2	Replacing the BOTTOM COVER ASSY	46
4.3.3	Replacing the OPEN COVER ASSY	48
4.3.4	Replacing the DISPENSER ASSY.....	51
4. 4	Printing Section	54
4.4.1	Replacing the Print Head (Thermal Head).....	54
4. 5	Paper Transfer Section	57
4.5.1	Replacing the Platen Roller	57
4.5.2	Replacing the Label Guide.....	58
4.5.3	Replacing the GEAR BOX SUB ASSY	60

4. 6	Sensors	62
4.6.1	Replacing the IM GAP FPC ASSY.....	62
4.6.2	Replacing the DISP NONSEPA.....	64
4.6.3	Replacing the IM GAP RELAY.....	68
4.6.4	Replacing the HEAD FPC ASSY.....	71
4. 7	PCBs and Electrical Parts	76
4.7.1	Replacing the PWR PCB.....	76
4.7.2	Replacing the CONT PCB.....	78
4.7.3	Replacing the speaker.....	81
4.7.4	Replacing the NFC PCB.....	83
4.7.5	Replacing the WLAN ANTENA SUB.....	85
5	Installation of Options	86
5. 1	Installing the Linerless kit.....	87
6	Troubleshooting	93
6. 1	About Error Message.....	93
6. 2	Error Code List.....	94
6. 3	Error List.....	96
6. 4	Status Icon List.....	108
7	Reference	112

1.1 About This Manual

This service manual gives all the information necessary for you to adjust and repair the PW4NX.

This service manual is written only for SATO authorized service personnel. The information in this manual is confidential to general users.

For basic specification, installation, operation and configurations of the printer, refer to the operator manual of the PW4NX.

Since all problems that may arise during adjustment and repair work cannot be described in this document, service personnel should always pay attention to safety in addition to the precautions described in this document.

1.2 Precautions

- Always power off the printer and disconnect the AC power cord from the outlet before you start any maintenance procedures including parts replacement.
- Wear a properly grounded static wrist strap as required during repair work.
- Wear proper gloves during adjustment and repair work.
- Do not touch the printing element with your bare hand when you replace the print head (thermal head).
- Hold the circuit board on the sides. Do not touch the components or bend the circuit board when you remove or install the circuit board.
- Do not touch the cutter with your hands, nor place objects into the cutter. Doing so could cause an injury.
- The print head (thermal head) will become hot after printing. Be careful not to touch it when replacing media or cleaning immediately after printing, to avoid being burned.

1.3 Parts Identification of the Printer

1.3.1 Front View

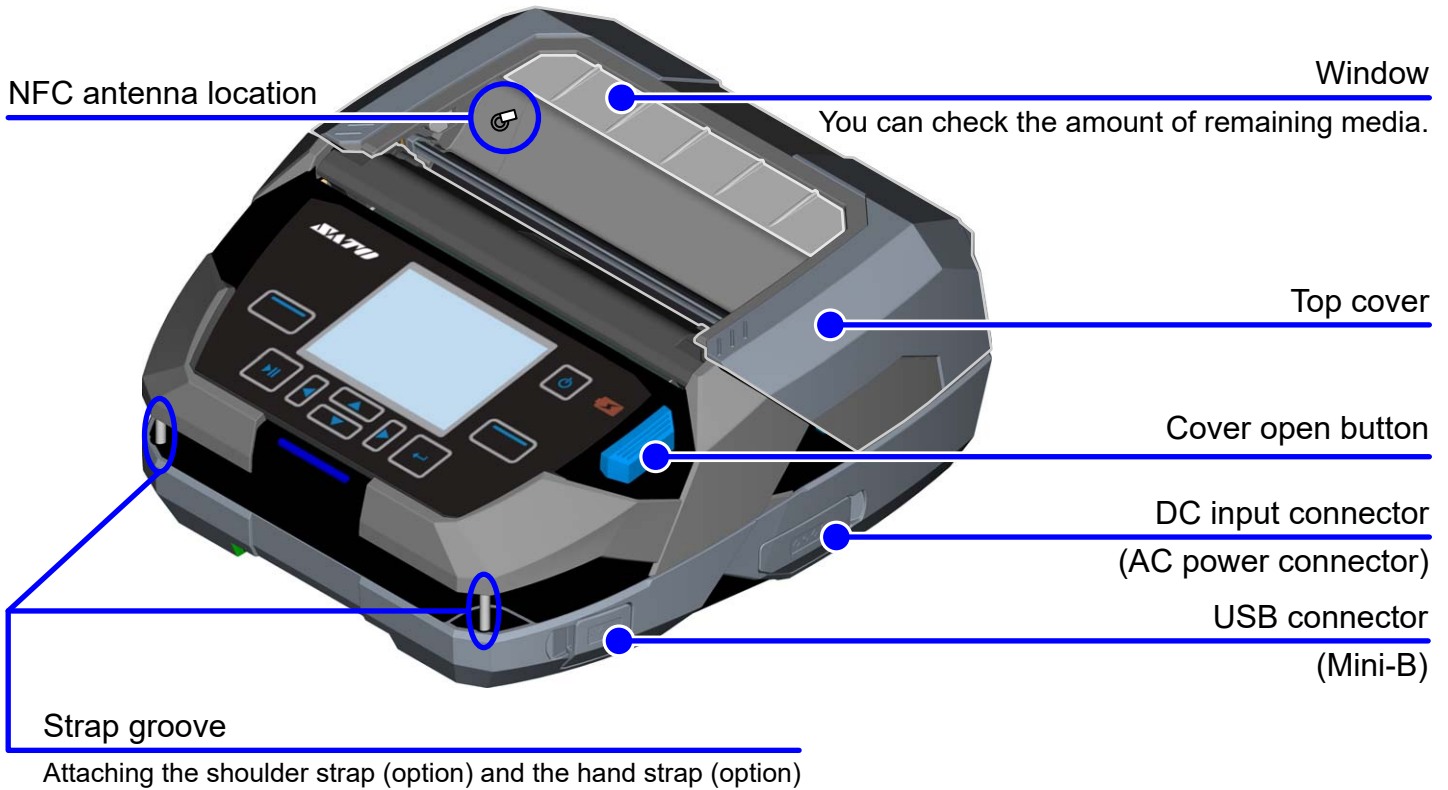

1.3.2 Rear View

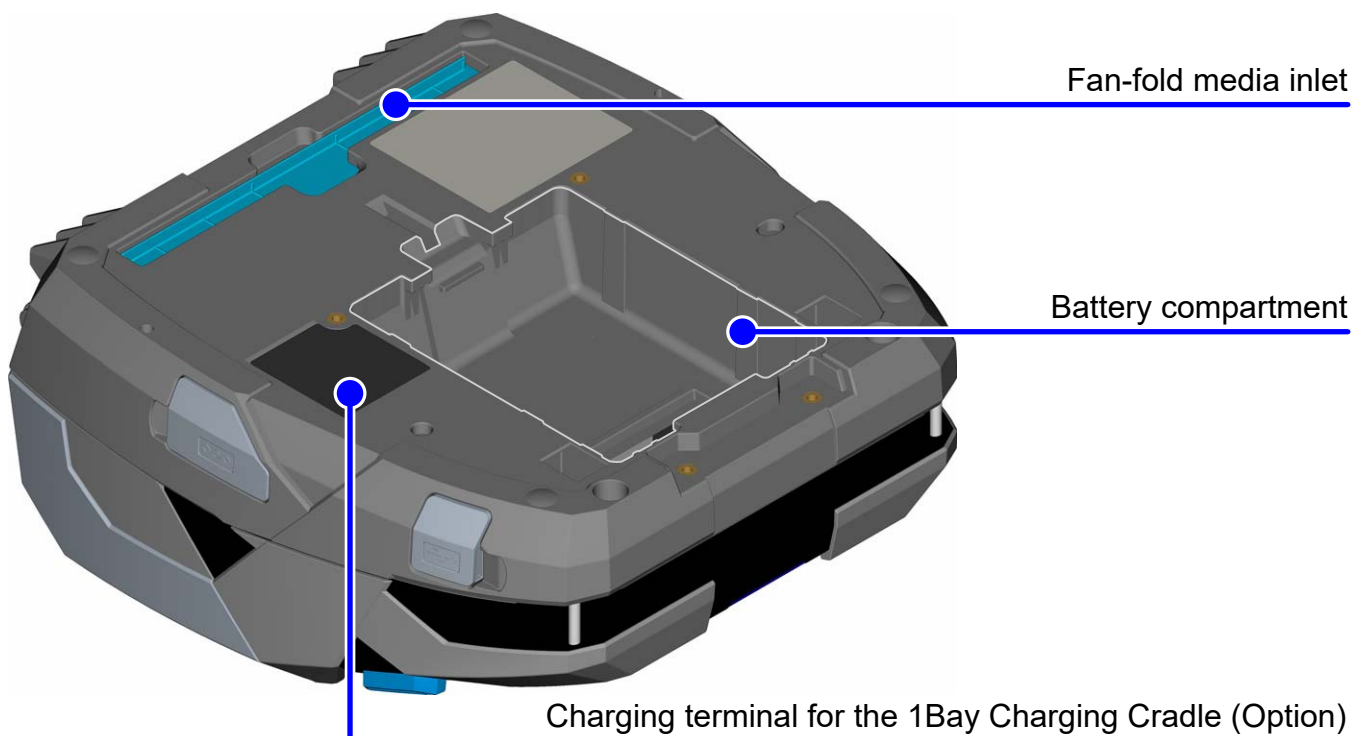

1.3.3 Internal View

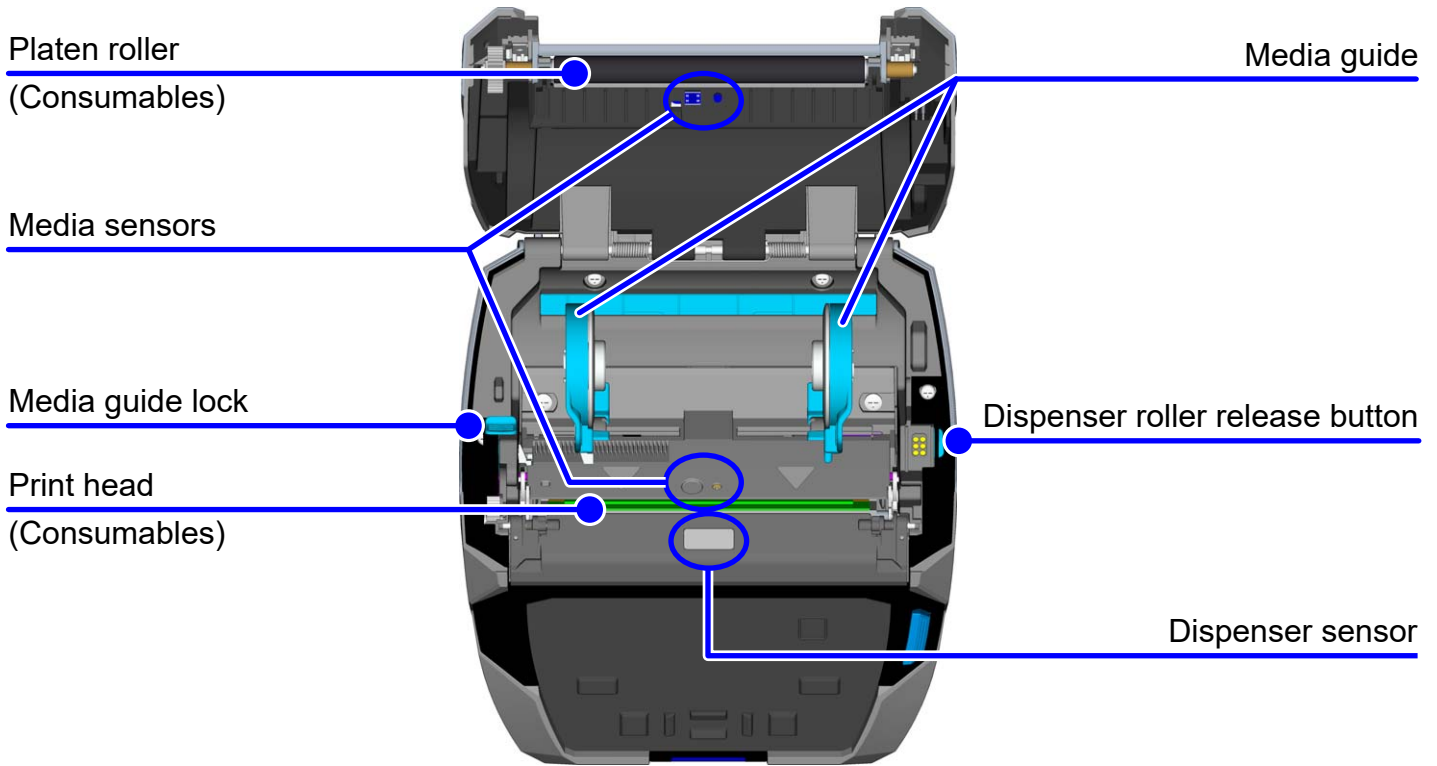

1.3.4 Operator Panel View

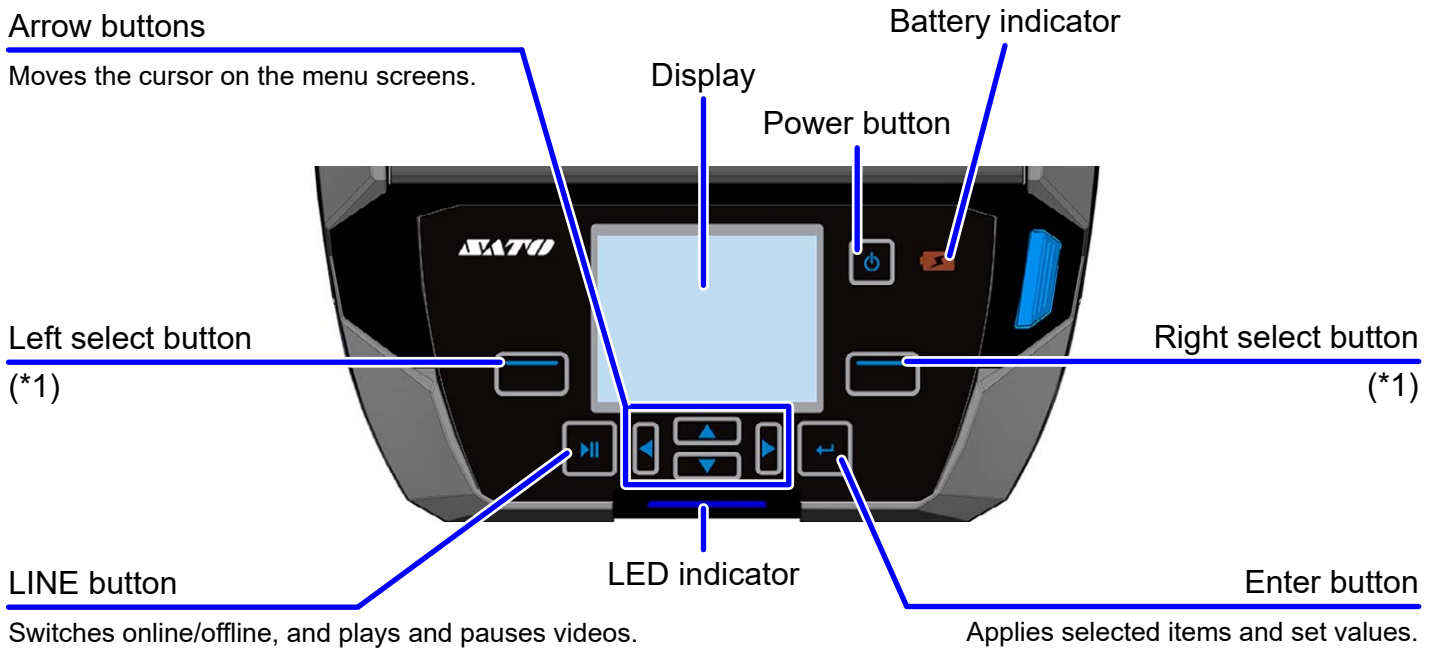

(*1) The functions differ according to the screen.
The functions of the buttons are shown at the bottom of the screen.

This chapter describes the following:

[2.1 About \[Settings\] menu](#)

[2.2 About \[Tools\] menu](#)

[2.2.1 Test Print](#)

[2.2.2 HEX-Dump](#)

[2.2.3 Reset](#)

[2.2.4 Install Certificates, Delete Certificates](#)

[2.2.5 Clone](#)

[2.2.6 Startup Guide](#)

[2.3 About \[Service Mode\]](#)

[2.3.1 Logging in Service Menu](#)

[2.3.2 Details of the Service Menu](#)

[2.3.3 Maintenance](#)







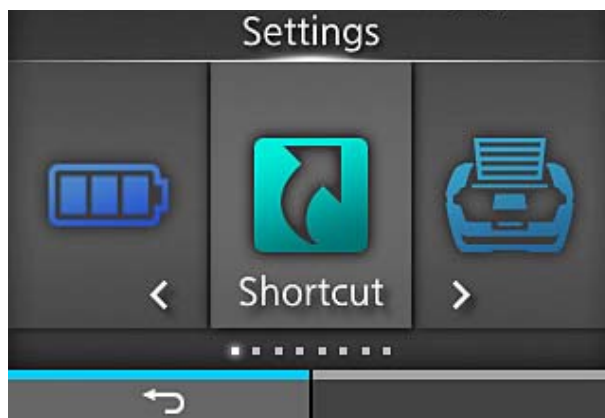

[2.3.4 Factory Offset](#)

[2.3.5 Factory Pitch](#)

[2.4 Checking and Updating the Firmware](#)

2.1 About [Settings] menu



Icon	Menu	Description
	[Printing]	Access the settings related to printing.
	[Interface]	Access the settings related to the interfaces.
	[Applications]	Access the settings related to the printer command.
	[System]	Access the settings related to the display language, buzzer volume, compatible mode, etc.
	[Tools]	Access the settings related to the media profiles editing, test print, initialization, etc.
	[Information]	Display the printer information and help videos.
	[Battery]	Access the battery condition information and charging settings.
	[Shortcut]	Directly access frequently used settings.

You can find the [Service] menu in the [Tools] menu.

However, users cannot access the [Service] menu without password.

This menu is only for SATO authorized service personnel use.

2.2 About [Tools] menu



Click on the items in blue to link directly to the details of the selected items.

Tools	Description
Test Print	
Factory	Perform the factory test print.
Configure List	Print the product setting information.
Configure QR	Print the configuration information with a QR code.
Paper Sensor	Print the detection result of the media sensor level.
BD address	Print the BD address.
Head Check	Perform the head check print.
HEX-Dump	Save the hex dump print data or dump data from the receive buffer to the USB memory.
Reset	Reset the printer settings.
Profiles	
Delete	Delete the profile.
Load	Load the profile.
Save	Save the current profile settings by overwriting.
Start with	Select the profile to be loaded at startup.
Service	Refer to 2.3 About [Service Mode]
Factory	Not available
Wi-Fi Site Survey	Survey the radio field strength of each access point and display or print it.
Install Certificates	Set the WLAN authentication.
Delete Certificates	Delete the WLAN authentication.
Clone	Copy the current product settings and installed data to the USB memory.
Logging Function	Enable, save, or delete the log information.
Startup Guide	Enable or disable the startup guide.

2.2.1 Test Print

Before starting work, print out the factory settings and check the following.

- Check the print position, sensor level, etc.
- Check the password for the [Service] menu

- 1 Place the label on the printer.
- 2 Select [Settings] > [Tools] > [Test Print] > [Factory] > [] (right select button).
- 3 After printing multiple labels, select [] (right select button) to stop the printing.

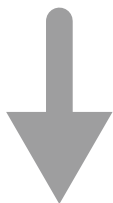
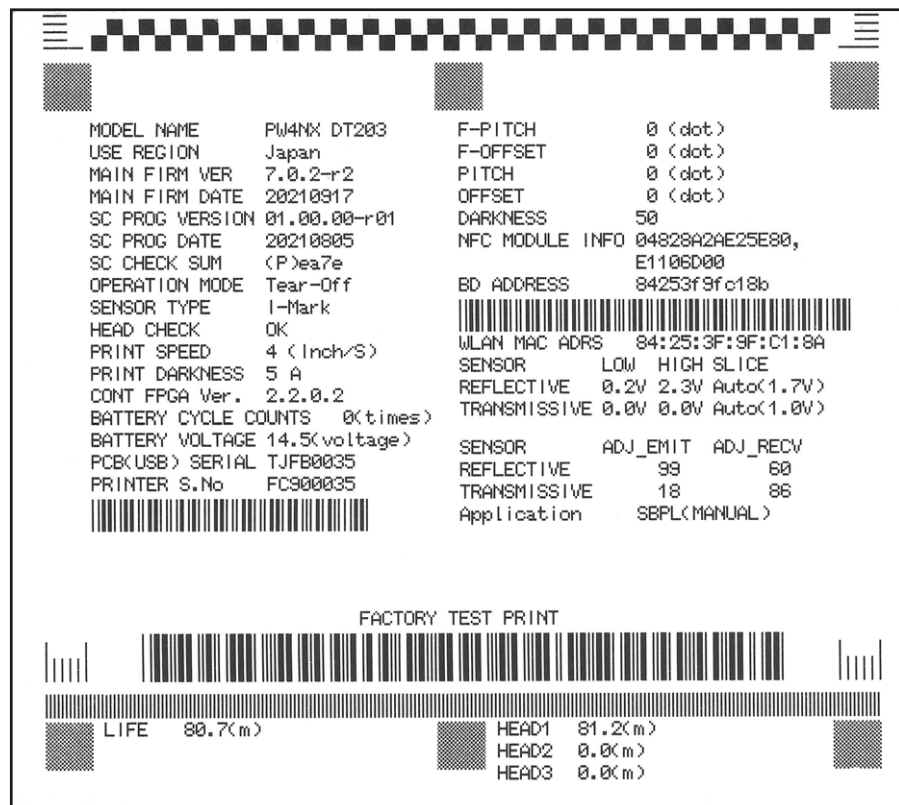
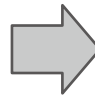

Media feed direction

2.2.2 HEX-Dump

Enable or disable the Hex Dump mode.

If you enable [Hex Dump Mode], the product prints the received data and at the same time creates a file of the received data inside “hexdump”.

If you return the setting to disabled, you can check the file on the screen.

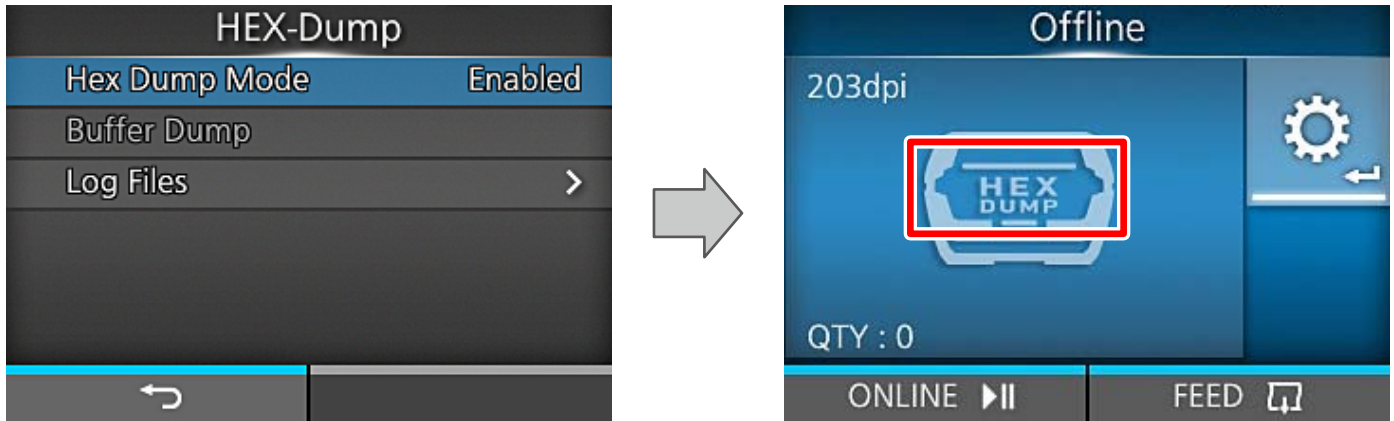

■ Buffer Dump

Save the receive buffer data to the product.

Available only if you disabled the [Hex Dump Mode] menu.

Tap [START] on the startup screen to save the data to the product.

Save the receive buffer data to “buff/” in the product.

■ Log Files

Save the receive buffer data to the product.

Copy	buff/	Copy the selected log file to the USB memory. [Tips] The data obtained by the buffer dump operation is stored.
	hexdump/	Copy the selected log file to the USB memory. [Tips] The data obtained by the hex dump (enabled) operation is stored.
Remove	buff/	Delete the log files of the printer.
	hexdump/	
Print	buff/	Print the selected log files.
	hexdump/	

2.2.3 Reset

Reset the printer settings.



Item	Description
Select	
Data	Initialize the setting values set in [Printing], [Interface], [Application] and [System]. [Tips] After initialization, the printer restarts automatically.
Data & Settings	Initialize the above data and the items selected from the following "Settings". [Tips] After initialization, the printer restarts automatically.
Settings	
User Reset	Initialize the setting values set in [Printing], [Interface], [Application] and [System].
User Reset (-Interface)	Initialize the same setting values as the "User Reset" except the settings in the [Interface] menu.
Factory Reset	Initialize to the status of factory shipment.
Factory Reset (-Interface)	Initialize to the status after factory shipment except for [Interface].
Interface	Initialize the setting values set in [Interface] main menu.
Printing	Initialize the setting values set in [Printing] main menu.

2.2.4 Install Certificates, Delete Certificates

Install/delete the certificates used for WLAN authentication and HTTPS.

Select [Tools] > [Install Certificates].

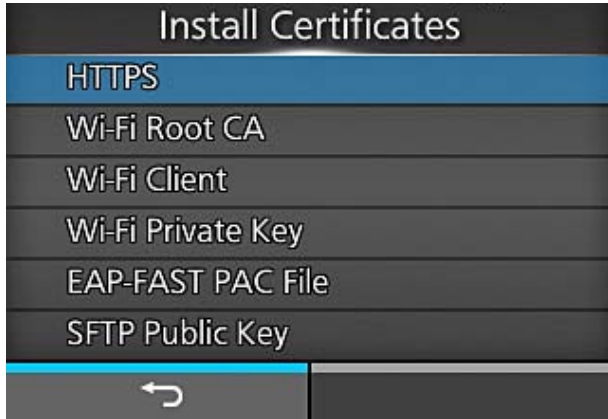

Select [Tools] > [Delete Certificates].

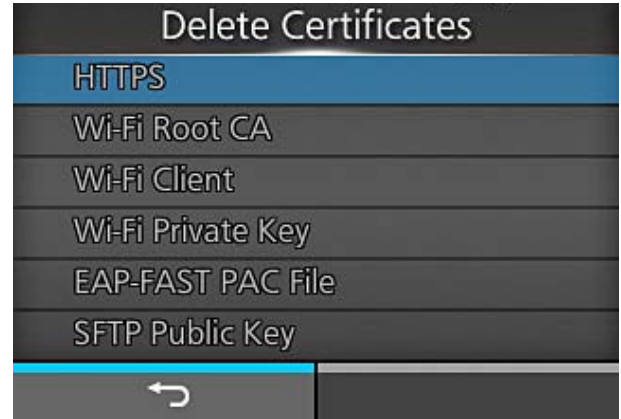

CAUTION

Certificate registration is enabled only when the USB memory in which the certificate file to be installed is stored in the root folder is connected to the USB connector on the back of the product.

The setting items are as follows:

HTTPS	Save the certificate files to the USB thumb drive memory's root folder. Acceptable file extensions are: <ul style="list-style-type: none"> • pem, .crt, .cer, .der for Root CA and client certificate in PEM or DER format. • pfx and .p12 for client certificates in PKCS #12 format. • prv and .key for private keys in PEM/PKCS#8 format. • pac for PAC files.
Wi-Fi Root CA	
Wi-Fi Client	
Wi-Fi Private Key	
EAP-FAST PAC File	

2.2.5 Clone

Copy the current printer settings and installed data to the USB memory.

Select [Tools] > [Clone].

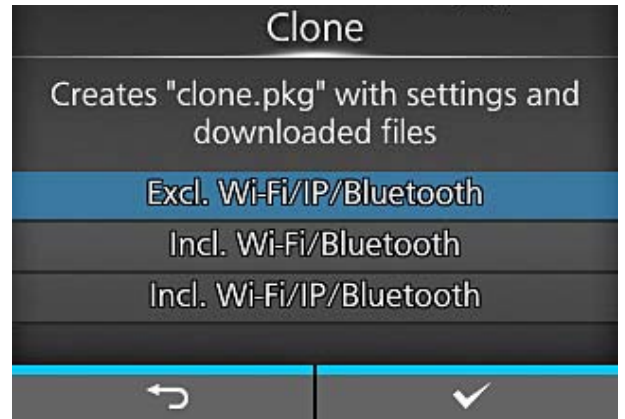

CAUTION

Available only if you have installed the USB memory.

Be sure to perform a virus check for the USB memory before connecting the USB memory to the printer.

[Tips]

Use the clone configuration when the printer will be replaced with a new printer, or when you set up multiple printers with same settings.

The setting items are as follows:

Excl. LAN/Wi-Fi/IP	Copy the printer settings and data, excluding network information, to the USB memory. This is useful when you set up multiple printers already configured for network with the same printer settings.
Incl. LAN/Wi-Fi	Copy the printer settings and data, including network information (excluding the IP address), to the USB memory. This is useful when you set up multiple printers to be connected to the same network with the same printer settings.
Incl. LAN/Wi-Fi/IP	Copy the printer settings and data, including network information (with the IP address), to the USB memory. This is useful when carrying over the settings of the printer to be replaced to a new printer.

2.2.6 Startup Guide

When the printer is turned on, the startup guide is displayed if it is enabled. (Default: Disabled)

Select [Tools] > [Startup Guide].

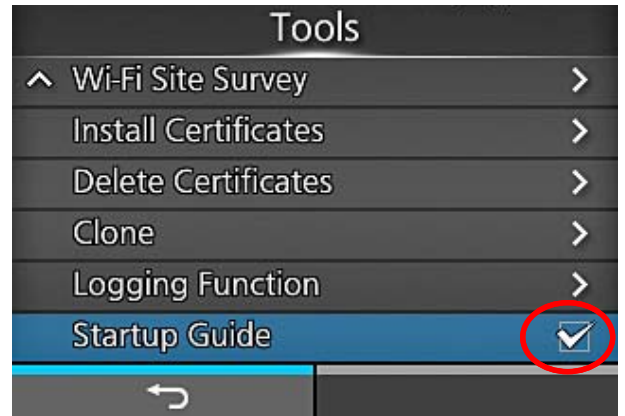

Perform the setting in the order of the following numbers.

1 Messages

Select the language displayed on the printer.



[Tips] When the NTP function is enabled, set the time zone (2).

2 Time Zone

Select the region and the city.

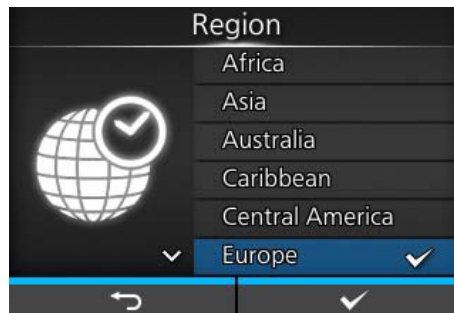

3 Print Mode

Select the operation mode.

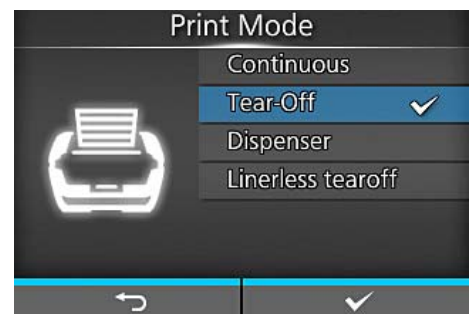

4 Sensor Type

[None] Disables the media sensor.

[Gap] Select this when using media with gaps.

[I-Mark] Select this when using media with I-marks.

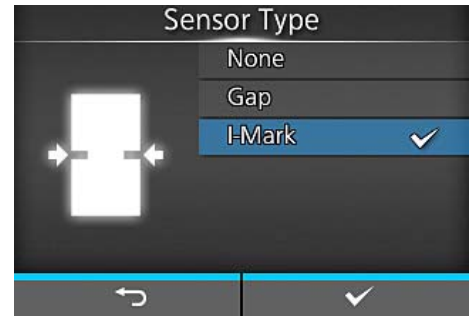

5 Video playback selection

Check video

[] (Enter key) → 6

End the Startup Guide

[] (Right select button) → 7



6 Video selection

Select a video.

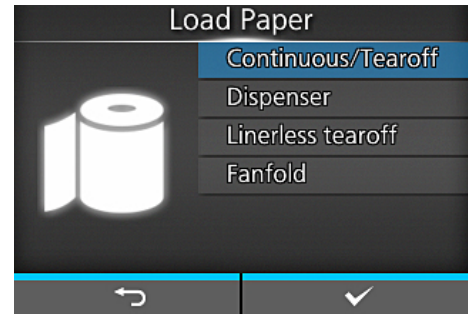

7 Selection whether to show the startup guide at the next startup.

Does not show the startup guide. [] (Right select button)

Shows the startup guide. [] (Left select button)

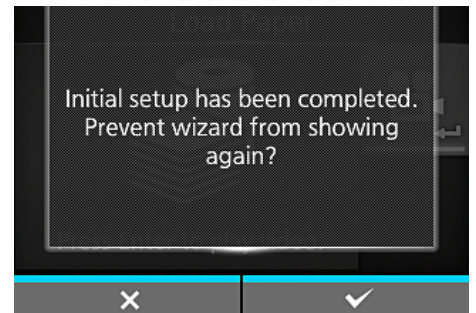

2.3 About [Service Mode]

2.3.1 Logging in Service Menu

CAUTION

You need to enter the password to access the [Service] menu. Since the serial number of the PCB is used as the password, the password is different for each product.

CAUTION

The [Service] menu is only for SATO authorized service personnel use.

1 Print the factory settings.

Refer to [3.1.3 Checking Printing with Factory Settings](#)

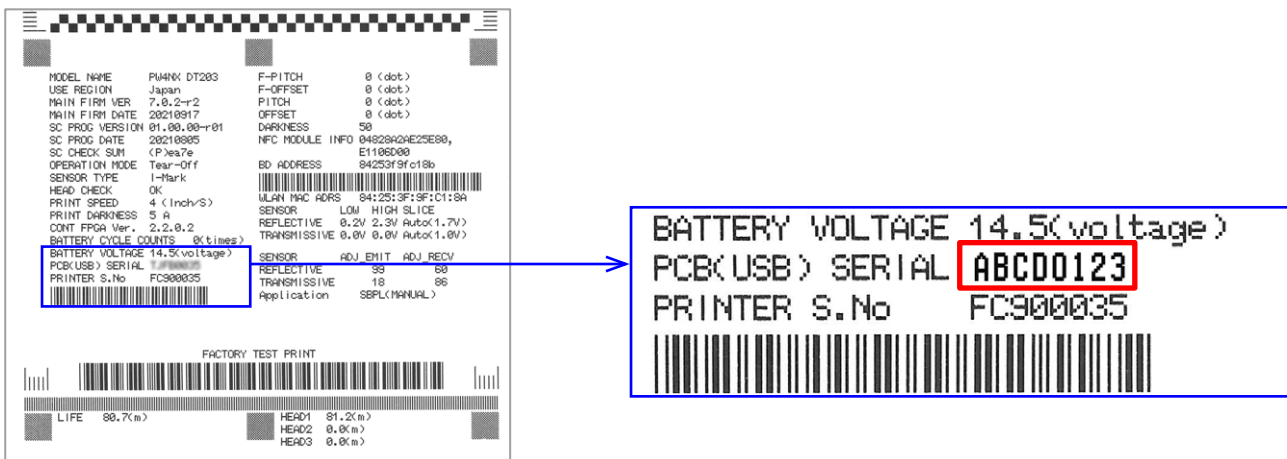

2 Enter the characters with "+" service" added to the PCB serial number (8 digits) on the printed label.

If the serial number shown above is printed: ABCD0123+service

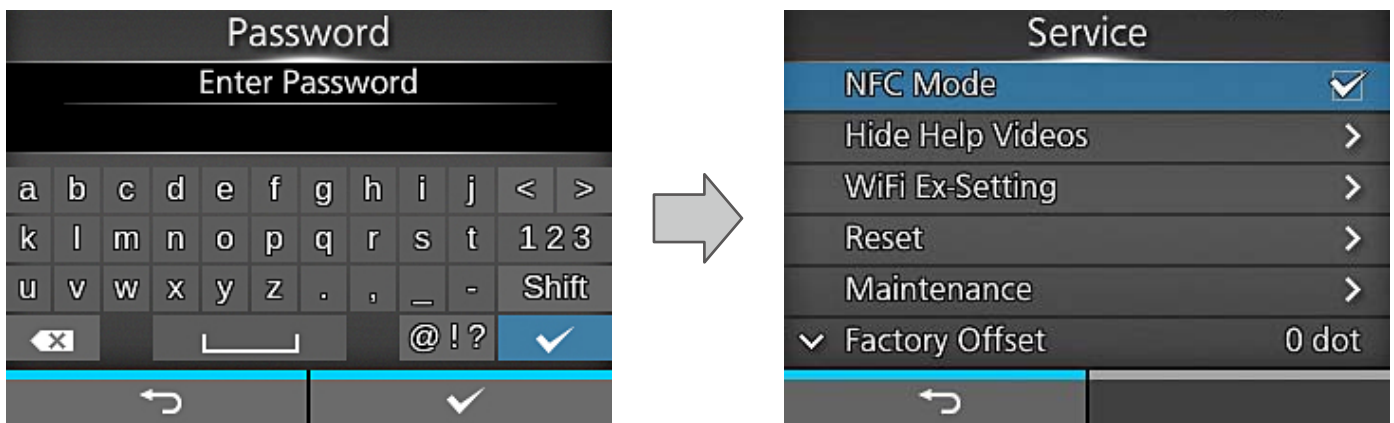

2.3.2 Details of the Service Menu

Item	Description
Service	
NFC Mode	Enable or disable the NFC function. (Default: Enabled)
Hide Help Videos	Check “Hide Help Video” to hide the help videos.
WiFi Ex-Setting	Configure the advanced wireless LAN settings.
Reset	Reset the printer settings. Refer to 2.2.3 Reset
Maintenance	Manually set the serial number of the printer or the USB.
Factory Offset	Correct the offset position.
Factory Pitch	Offset the print position in the vertical direction.
Check Communication	Configure the Check Communication settings.

2.3.3 Maintenance

Select [Service] > [Maintenance].

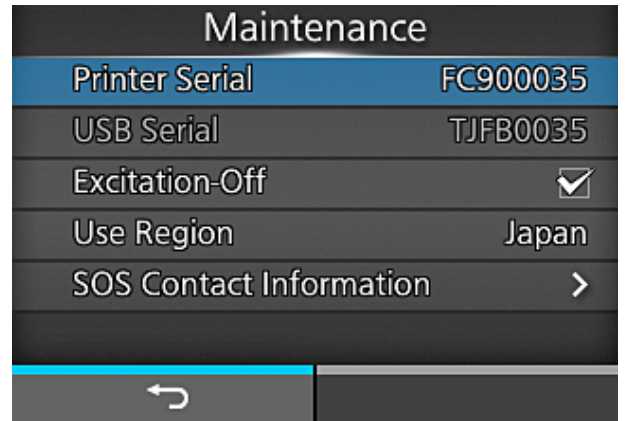

Printer Serial	Set manually the printer’s Serial number whenever the CONT PCB is replaced.
USB Serial	Enable or disable the function to change the USB serial number. (Default: Disabled) Disabled: Cannot change the USB serial number. Enabled: Can change the USB serial number. To change the USB serial number, check the “Change USB Serial” in Offline > [Settings] > [Interface] > [USB].
Excitation-Off	Enable or disable the function. (Default: Enabled)
Use Region	Select Japan or Other.
SOS Contact Information	Enter the phone number of the SOS contact information.

2.3.4 Factory Offset

Select [Service] > [Offset].



Correct the offset position.

Set the offset value "+" to move the stop position in the direction opposite to the media feed direction and value "-" to move the stop position in the media feed direction.

Offset position refers to the tear-off position, cut position and dispense stop position.

Setting range: -99 to 99 dots (Default: 0 dots)

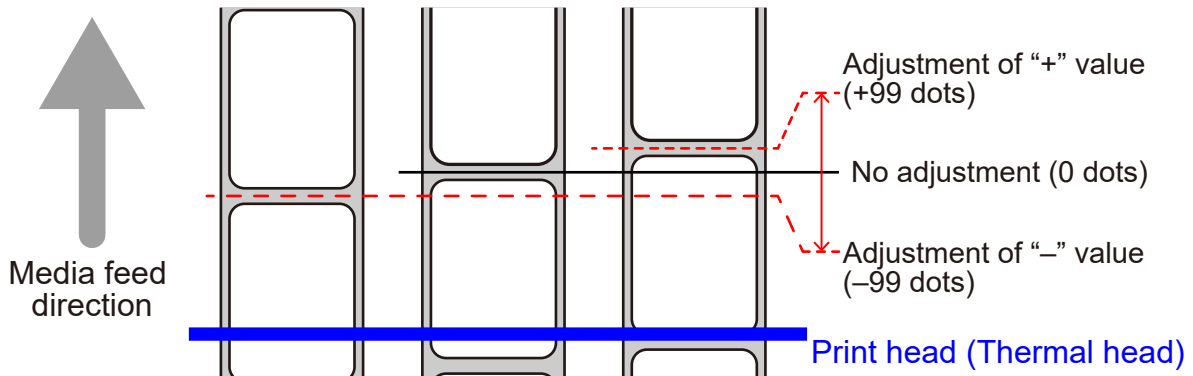

[Tips]

- The actual offset position is the sum of the offset value set here and the offset value set for print position, in Service menu.
- When you change the offset value in the Service menu, the offset value set at factory shipment also changes.

2.3.5 Factory Pitch

Select [Service] > [Factory Pitch].



To shift the print position in the vertical direction.

Set the print position "+" to move the position in the direction opposite to the media feed direction and value "-" to move the position in the media feed direction.

Setting range: -99 to 99 dots (Default: 0 dots)

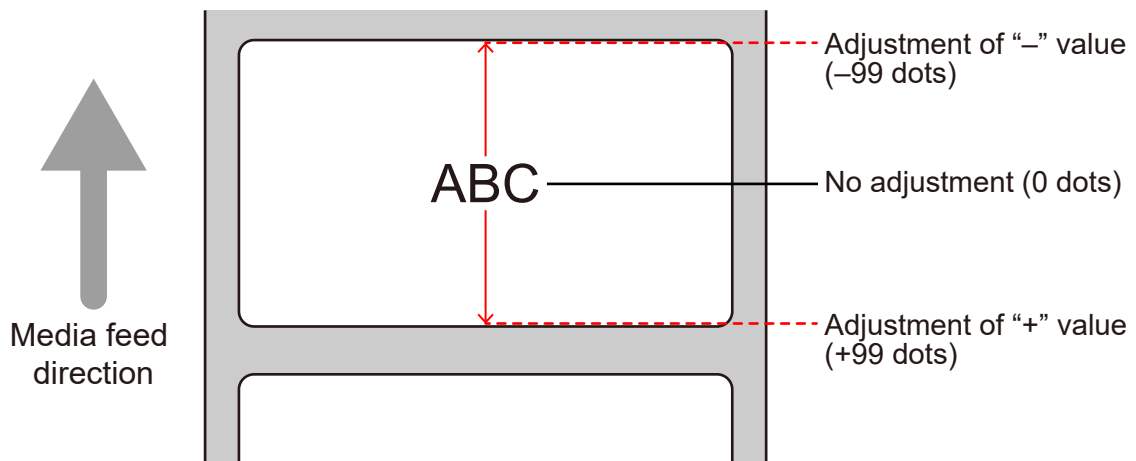

[Tips]

- The actual offset of the print position in the vertical direction is the sum of the offset value and the print position offset value set in Service menu.
- When you change the value in the Service menu, the value set at factory shipment also changes.

2.4 Checking and Updating the Firmware

■ Checking the Firmware

Select [Information] > [Build Version].

Check the version name.

Build Version	
Name	
Date	
Checksum	
Kernel Version	>
Boot Version	>

■ Updating the Firmware

CAUTION

Be sure to perform a virus check for the USB memory before connecting it to the printer.

CAUTION

Firmware updating can be done by using either a “pkg” file or “img” file.

- 1 Prepare a pkg (img) file used for firmware updating and copy it to the root directory of the USB memory.
- 2 Attach the USB memory to the USB host cable (Mini-B) and then connect it to the USB connector (Mini-B) of the printer.
- 3 Power on the printer.
- 4 Display the version to be updated.
- 5 Select [] (right select button) to start updating.
- 6 When the update is complete, the printer restarts automatically.

This chapter describes the following:

[3.1 Checking Before Starting Work](#)

[3.1.1 Checking Printing with Actual User Data](#)

[3.1.2 Checking Installation Environment and Printer Conditions](#)

[3.1.3 Checking Printing with Factory Settings](#)

[3.1.4 Disabling the SOS Connection](#)

[3.1.5 Checking the Battery Status](#)

[3.2 Checking and Cleaning](#)

[3.2.1 Checking and Cleaning the Print Head \(Thermal Head\)](#)

[3.2.2 Checking and Cleaning the Platen Roller](#)

[3.2.3 Checking and Cleaning the Media Sensors](#)

[3.3 Checks and Adjustments](#)

[3.3.1 Checking and Adjusting the I-mark Sensor and Gap Sensor](#)

[3.3.2 Printing Quality](#)

[3.3.3 Meandering](#)

[3.3.4 Checking and Adjusting the Print Position](#)

[3.3.5 Checking the Stop Position](#)

[3.4 Final Check](#)

[3.4.1 Checking Test Print with Factory Settings](#)

[3.4.2 Checking the Customer's Layout](#)

[3.4.3 Checking Barcode Scan](#)

[3.4.4 Checking SOS Connection](#)

[3.4.5 Returning to the Original State](#)

3.1 Checking Before Starting Work

This section describes the items to be checked before starting work.

3.1.1 Checking Printing with Actual User Data



1 min

Make sure to perform print check using actual user data.

[Tips]

When multiple layouts are used for printing, make sure to check for every layout.



Check & Point

- ① Is the print position correct in the horizontal and vertical directions?
- ② Is the print quality good? Make sure no blurred printing occurs in the horizontal and vertical directions and also no sticking occurs.
- ③ Is the media stop position correct?

3.1.2 Checking Installation Environment and Printer Conditions



1 min

Check the user's printer usage environment, label placing conditions, etc.





Check & Point

- ① Is the label placed in the proper position?
- ② Is there any excessive load on the routed wirings?
- ③ Is there any problem with the label expiration date?
- ④ Is the genuine label used?

3.1.3 Checking Printing with Factory Settings



- 1 Place the label on the printer.
- 2 Select [Settings] > [Tools] > [Test Print] > [Factory] > [] (right select button).
- 3 After printing multiple labels, select [] (right select button) to stop the printing.

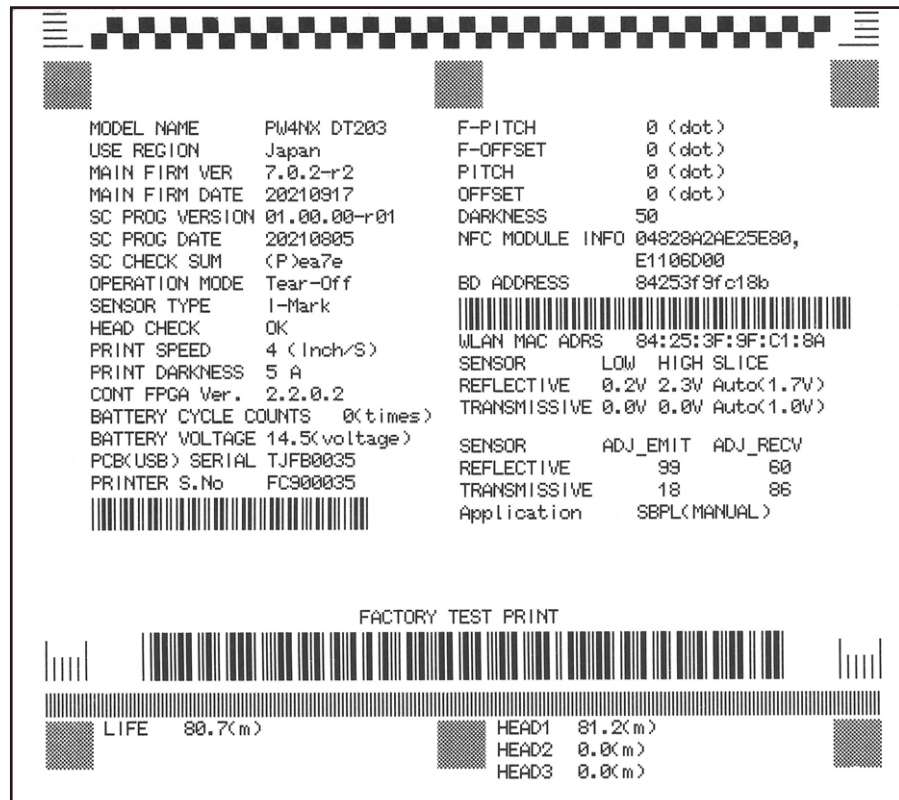

Media feed direction



Check & Point

- ① Is there any abnormal noise?
- ② Check the print position and stop position.
Print on multiple labels and check that the position of each block is stable.
- ③ Firmware version
Update the firmware version as required.
- ④ Check the head counter information.
- ⑤ The password for the [Service] menu
- ⑥ Check the sensor levels.
If the sensor level is outside of the following range, adjust the sensor level.

Voltage	REFLECTIVE	TRANSMISSIVE
LOW	0.5 V or less	
HIGH	High – Low \geq 1.0 V	

Refer to [3.1.3 Checking Printing with Factory Settings](#)

```

MODEL NAME      PW4NX DT203      F-PITCH        0 (dot)
USE REGION      Japan          F-OFFSET       0 (dot)
MAIN FIRM VER   7.0.2-r2      PITCH         0 (dot)
MAIN FIRM DATE  20210917      OFFSET        0 (dot)
SC PROG VERSION 01.00.00-r01  DARKNESS      50
SC PROG DATE   20210805      NFC MODULE INFO 04828A2AE25E80,
SC CHECK SUM   <P>ea7e      E1106D00
OPERATION MODE Tear-Off      BD ADDRESS     84253f9fc18b
SENSOR TYPE     I-Mark
HEAD CHECK      OK
PRINT SPEED     4 (Inch/S)
PRINT DARKNESS 5 A
CONT FPGA Ver. 2.2.0.2
BATTERY CYCLE COUNTS 0(times)
BATTERY VOLTAGE 14.5(voltage)
PCB(USB) SERIAL TJFB0035
PRINTER S.No   FC900035
WLAN MAC ADRS  84:25:3F:9F:C1:8A
SENSOR          LOW  HIGH  SLICE
REFLECTIVE     0.2V 2.3V Auto<1.7V>
TRANSMISSIVE   0.0V 0.0V Auto<1.0V>
SENSOR          ADJ_EMIT  ADJ_REC
REFLECTIVE     99        80
TRANSMISSIVE   18        86
Application    SBPL(MANUAL)
    
```

FACTORY TEST PRINT

```

LIFE  80.7(m)
HEAD1 81.2(m)
HEAD2 0.0(m)
HEAD3 0.0(m)
    
```

CAUTION

After completion of the above check, print various setting information so that you can check it later.

3.1.4 Disabling the SOS Connection



When performing inspections and repairs, notification information is sent, so disable the SOS mode.

- 1 Select [Settings] > [Interface] > [Network] > [Services] > [Online services].
- 2 Check that the SOS mode is set to Disabled.

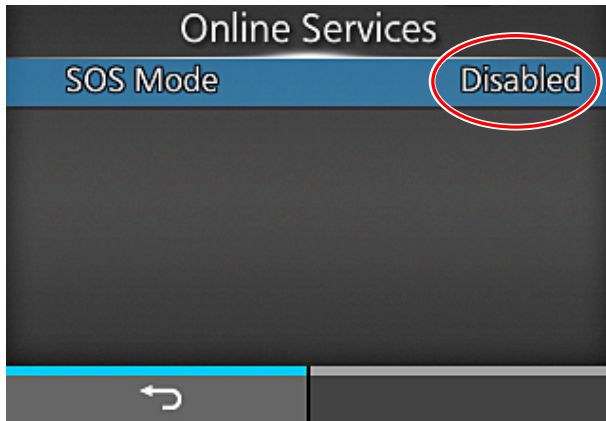

3.1.5 Checking the Battery Status



- 1 Select [Settings] > [Battery].
- 2 Check the battery status. (Good/Replace/Poor)

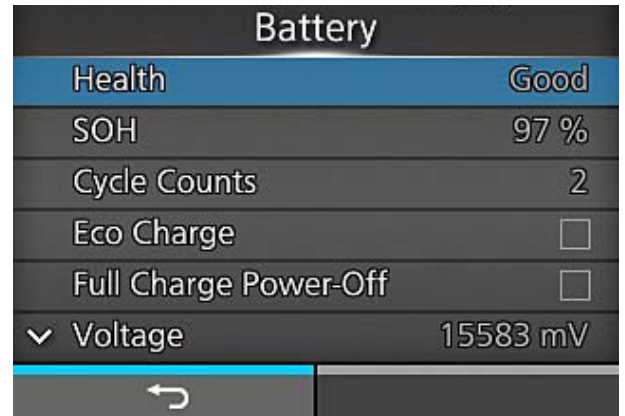

[Tips] Battery status

A message is displayed when the SOH or cycle count is as follows.

SOH	Cycle count	Message
80% or more	400 times or less	
79 - 70%	401 - 500 times	Replacement recommendation message
60 - 69%	501 - 600 times	Replacement warning message
59% or less	601 times or more	Battery deterioration error display

3.2 Checking and Cleaning

While cleaning parts, perform the relevant checks.

3.2.1 Checking and Cleaning the Print Head (Thermal Head)



1 min

Clean the print head (thermal head) using the printer cleaning liquid.

CAUTION

Do not use organic solvents.
Use IPA (Isopropyl alcohol).



Check & Point

Check the head counter before cleaning. If the counter value is close to the guaranteed value, check the print head (thermal head) and, if it is worn out, replace it with a new one.

Refer to [4.4.1 Replacing the Print Head \(Thermal Head\)](#)

3.2.2 Checking and Cleaning the Platen Roller



1 min

Clean the platen roller using the printer cleaning liquid.

CAUTION

Do not use organic solvents.
Use IPA (Isopropyl alcohol).



Check & Point

Check the counter before cleaning. If the counter value is close to the guaranteed value, check the platen roller and, if it is worn out, replace it with a new one.

Refer to [4.5.1 Replacing the Platen Roller](#)

3.2.3 Checking and Cleaning the Media Sensors



3 min

Check that no cracks or breakage appear on the exterior before cleaning each part.

- Print Head (Thermal Head)
- Each sensor
- Route where label contacts

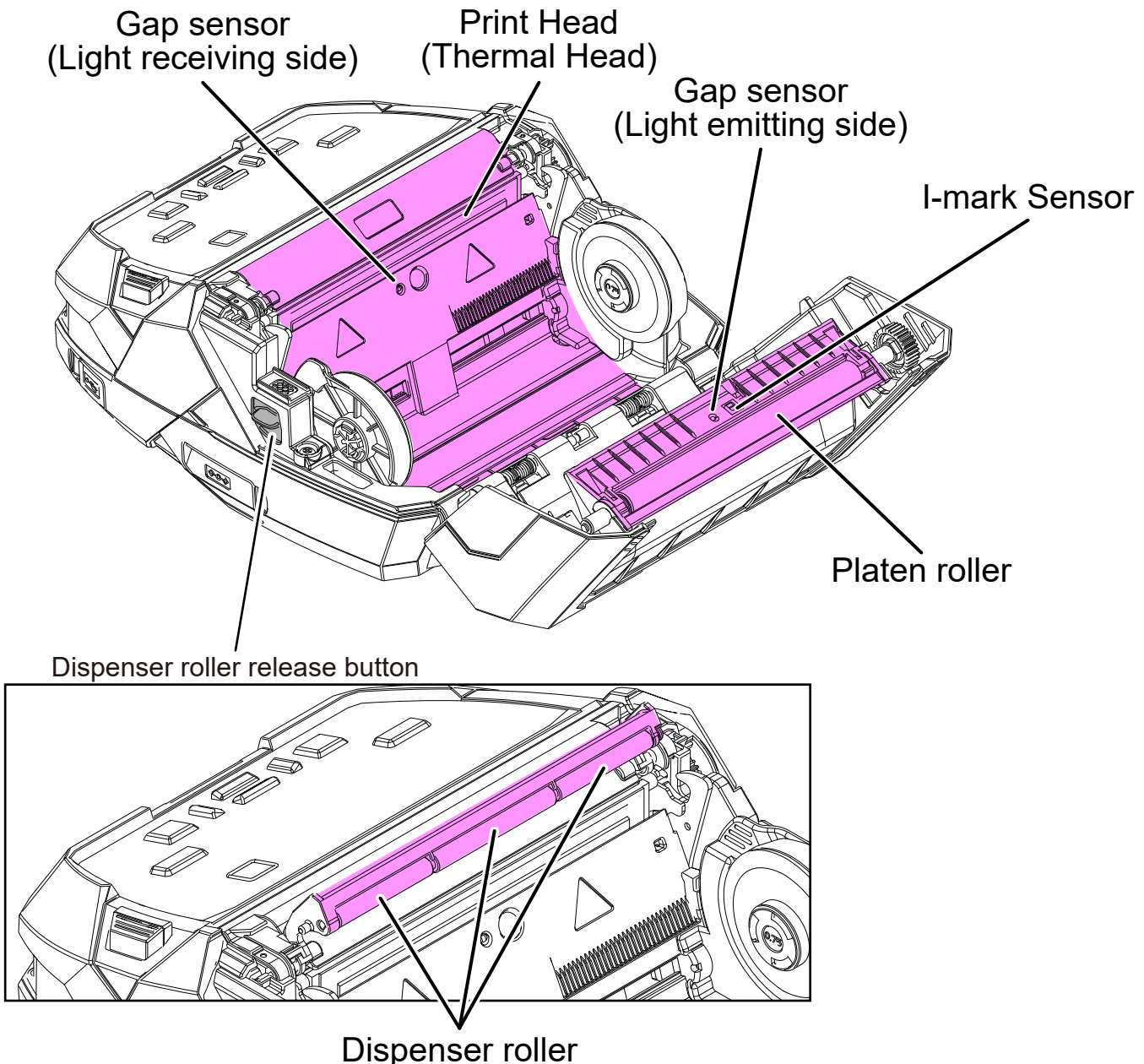

- ✓ Press the dispenser roller release button, and pull out the dispenser unit. Then, you can access the dispenser rollers.

3.3 Checks and Adjustments

Check respective items before starting work. For the item judged to be adjusted, perform necessary adjustments.

3.3.1 Checking and Adjusting the I-mark Sensor and Gap Sensor





■ Auto-calibration

- 1 Select [Printing] > [Advanced] > [Calibrate] > [Auto-calibration] > [Gap+I-Mark].

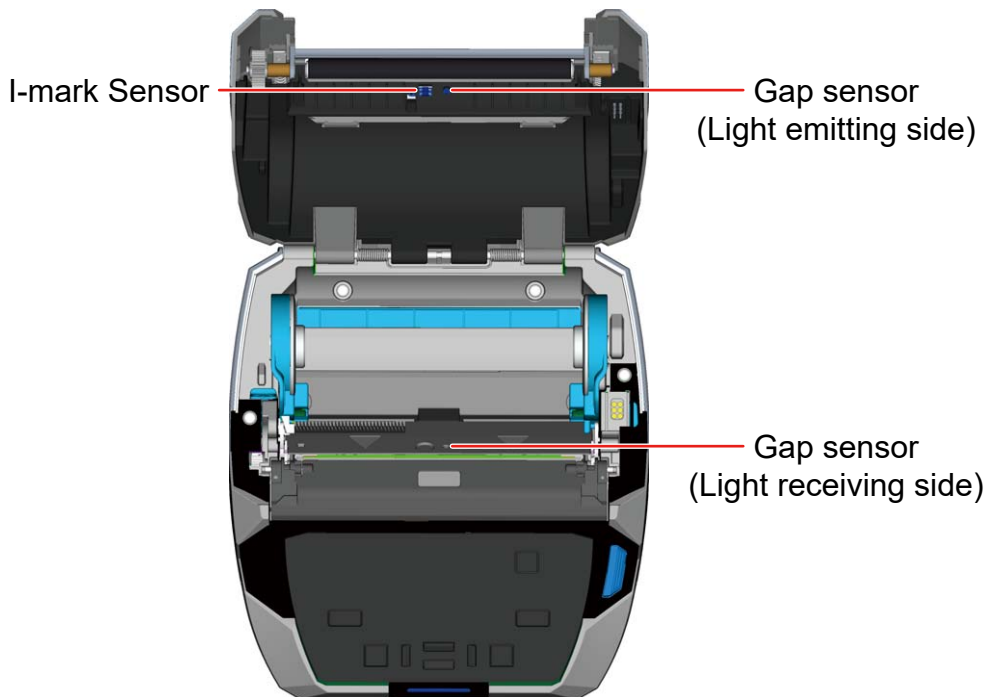

- 2 Remove the labels from the liner and place the liner so that the I-mark does not cover the GAP sensor.



- 3 Select [START] (right select button) > [] (right select button).
Then, the sensor adjustment is automatically performed and shows the results.

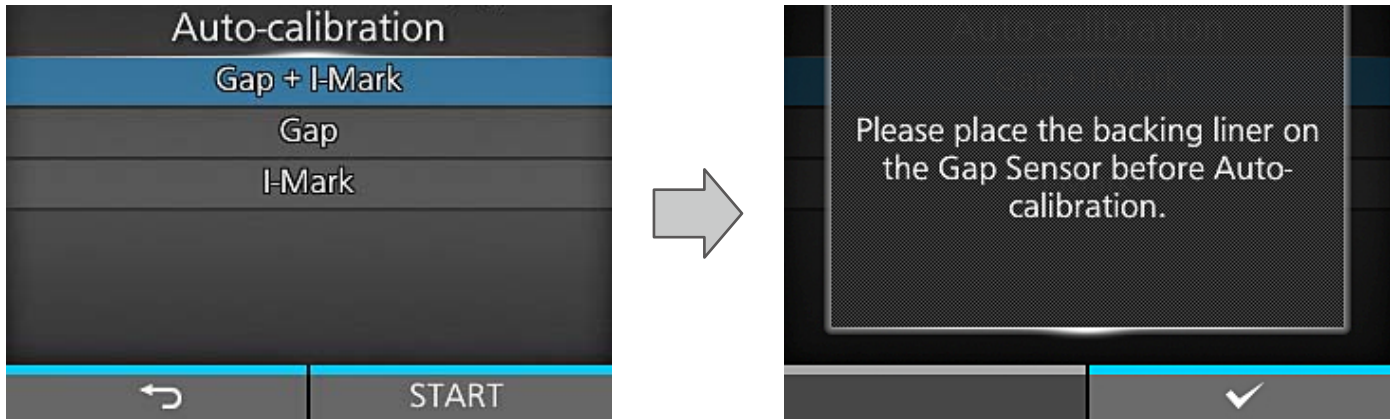

[Tips]

When the printer shows a “Calibration failed” message, place the liner correctly and perform the auto-calibration operation again.

The I-mark slice level is automatically adjusted by the following formula.

$$\text{I-mark slice level} = (\text{High level} - \text{Low level}) \times 0.7 + \text{Low level}$$

■ Adjusting the Gap Sensor Manually

- 4 Remove the labels from the liner and set the liner.

- 5 Select [Printing] > [Calibrate] > [GAP Levels].

- 6 Check and adjust the sensor low level and note the low level value.

Check

Check that the sensor Level is less than 0.5 V

Adjustment

Adjust the sensor level by changing the value of the Emit level.

If the sensor level does not fall below 0.5 V, adjust it by changing the value of the Receive level.

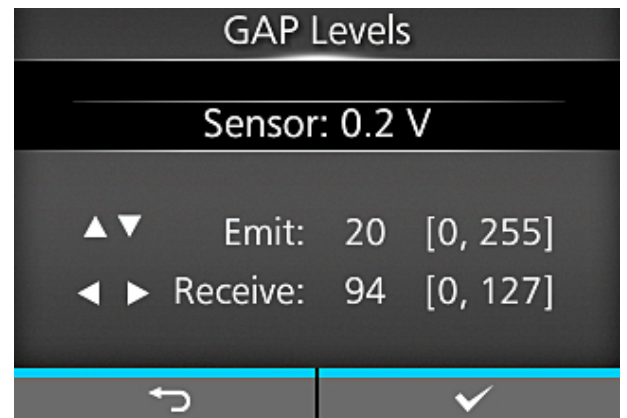

- 7 With the screen as it is, set the media so that the label part is on the gap sensor.

[Tips] For the sensor position, refer to step 2 of “Auto-calibration”.

- 8** Check and adjust the sensor high level and note the high level value.

Check

Check that the sensor level satisfies the following conditions.

High level – Low level \geq 1.0 V

The Low level is below 0.5 V.

Adjustment

Adjust the sensor level by changing the value of the Emit level and Receive level.

- 9** Select [Calibrate] > [GAP Slice Level].

- 10** You can set the slice level arbitrarily.

[Tips] When the slice level is 0, the slice level is automatically set.

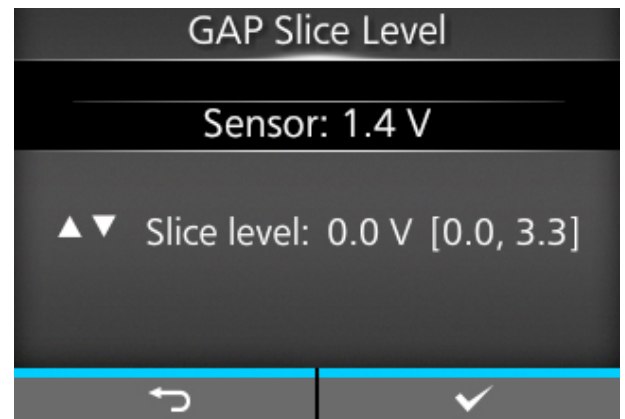
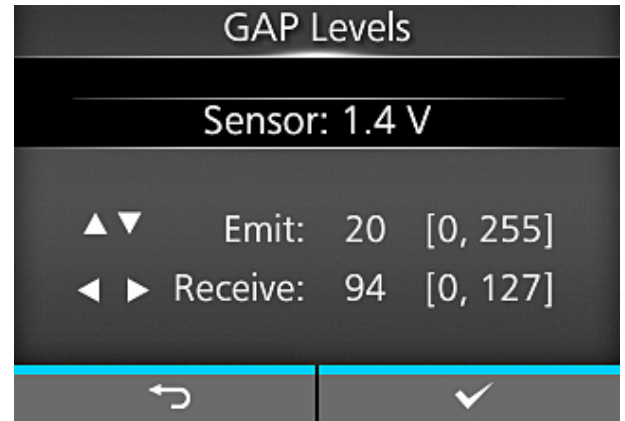

■ Adjusting the I-mark Sensor Manually

- 11** Place the label so that the I-mark does not cover the I-mark sensor.

[Tips] For the sensor position, refer to step 2 of “Auto-calibration”.

- 12** Select [Calibrate] > [I-Mark Levels].

- 13** Check and adjust the sensor low level and note the low level value.

Check

Check that the sensor level is less than 0.5 V.

Adjustment

Adjust the sensor level by changing the Send Gap Level.

If you cannot set the sensor level to less than 0.5 V, change the Receive Gap Level.

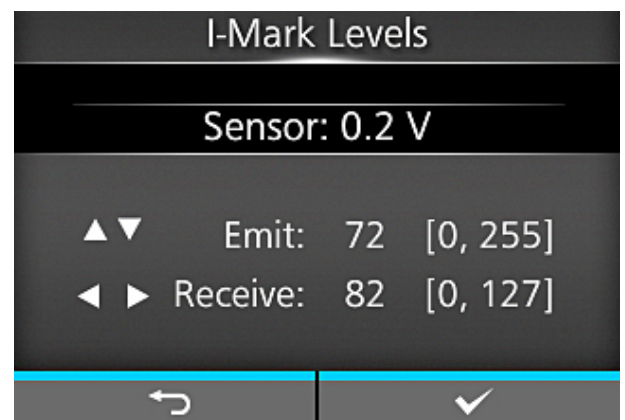

14 Without changing the screen, place the liner so that the I-mark on the liner is right on the I-mark sensor.

[Tips] For the sensor position, refer to step 2 of “Auto-calibration”.

15 Check and adjust the sensor high level and note the high level value.

Check

Check that the sensor level satisfies the following condition.

High level (I-mark sensor) – Low level ≥ 1.0 V

Adjustment

Adjust the sensor level by changing the Send Gap Level and Receive Gap Level.

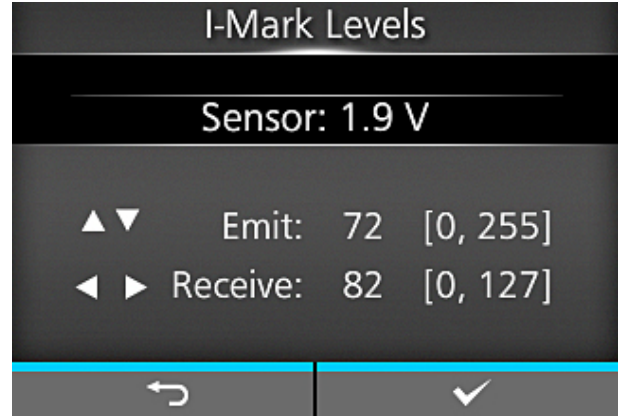

16 Select [Calibrate] > [I-Mark Slice Level].

17 You can set the slice level arbitrarily.

[Tips]

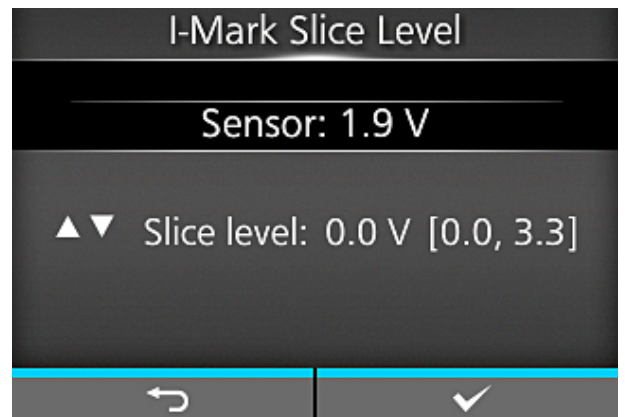

When the slice level is 0, the slice level is automatically set.



3.3.2 Printing Quality



Perform the test print with the factory settings and check that there is no problem with printing quality.

- 1 Place the label on the printer.
- 2 Select [Settings] > [Tools] > [Test Print] > [Factory] > [] (right select button).
- 3 After printing multiple labels, select [] (right select button) to stop the printing.

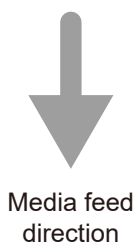
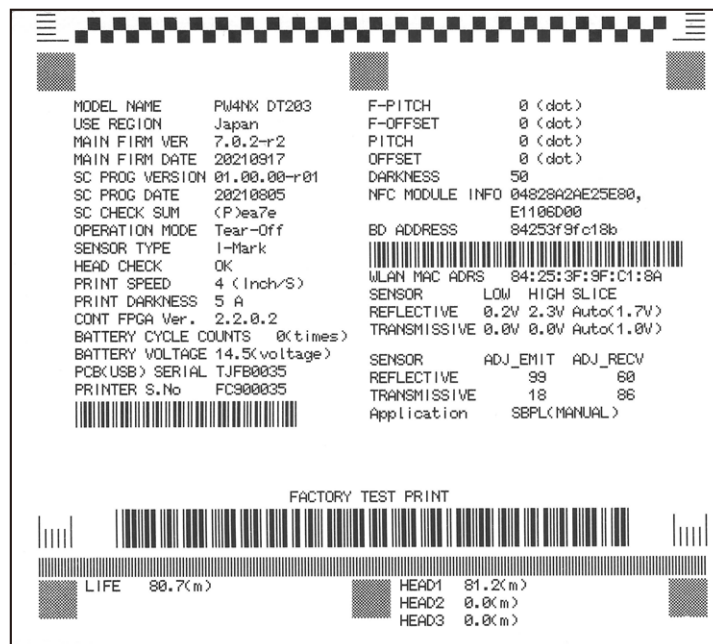

Check & Point

- ① Is there any quality degradation compared with the test print before starting work?
- ② Is the print quality uniform?
If the print quality is not uniform and hard to correct, lower the print darkness, and then check the test print results again.
- ③ Is printing shrunk
Pay attention to the ruled lines. If the ruled lines are missing, check the drive part as it may be the cause.

3.3.3 Meandering



1 min

Perform the test print with the factory settings and check that the printing is not meandering in horizontal direction.



Check & Point

- ① Is the media meandering?
If you cannot eliminate the meandering, replace the roller.
- ② After installing all the units, check for meandering again.

3.3.4 Checking and Adjusting the Print Position



1 min

Perform the test print with the factory settings and check that no print position deviation occurs. If it occurs, perform adjustment to correct it.

[Tips]

When you have adjusted the sensor levels, be sure to check the print position.



Check & Point

Check that the print position on the 1st and 3rd labels is stable.
If the problem persists, perform sensor adjustment again and recheck the roller, etc.

3.3.5 Checking the Stop Position



1 min

Perform the test print with the factory settings and check that no stop position deviation occurs. If it occurs, perform adjustment to correct it.

[Tips]

When you have adjusted the sensor levels, be sure to check the stop position.



Check & Point

- ① Check that the stop position on the 1st and 3rd labels is stable.
- ② No print skips occurs.
If the problem persists, perform sensor adjustment again and recheck the roller, etc.

3.4 Final Check

3.4.1 Checking Test Print with Factory Settings



1 min

After finishing work, make sure that you haven't accidentally changed something.



Check & Point

- ① All setting items
- ② Print position
- ③ Stop position

[Tips]

If there is an item unable to check, check it with the internal setting information, as required.

3.4.2 Checking the Customer's Layout



1 min

Ask the customer to print out with actual data, and make sure that there is no problem with the layout.

3.4.3 Checking Barcode Scan



1 min

When the customer's layout includes barcodes, QR codes, etc., perform readout checks to make sure that a scanner can read them correctly.

3.4.4 Checking SOS Connection



5 min

Check the SOS connection status and take an appropriate action according to the connection type.



Check & Point

- ① On demand...Read an error code.
 - ② Real time...Check that there is no problem with the communication state.
-

3.4.5 Returning to the Original State



3 min

Check that the printer configuration is the same as that before starting the service work.

The replacement procedures described in this chapter are as follows:

[4.1 Notes on Replacing Parts](#)

[4.2 EXPLODED VIEW](#)

[4.3 Case Cover](#)

[4.3.1 Replacing the TOP COVER ASSY](#)

✓ LCD MODULE

[4.3.2 Replacing the BOTTOM COVER ASSY](#)

[4.3.3 Replacing the OPEN COVER ASSY](#)

[4.3.4 Replacing the DISPENSER ASSY](#)

[4.4 Printing Section](#)

[4.4.1 Replacing the Print Head \(Thermal Head\)](#)

[4.5 Paper Transfer Section](#)

[4.5.1 Replacing the Platen Roller](#)

[4.5.2 Replacing the Label Guide](#)

[4.5.3 Replacing the GEAR BOX SUB ASSY](#)

[4.6 Sensors](#)

[4.6.1 Replacing the IM GAP FPC ASSY](#)

- ✓ IM, Gap Sensor (Transmitter), Cover Open Sensor

[4.6.2 Replacing the DISP NONSEPA](#)

[4.6.3 Replacing the IM GAP RELAY](#)

[4.6.4 Replacing the HEAD FPC ASSY](#)

- ✓ Gap Sensor (Receiver)

[4.7 PCBs and Electrical Parts](#)

[4.7.1 Replacing the PWR PCB](#)

[4.7.2 Replacing the CONT PCB](#)



[4.7.3 Replacing the speaker](#)

[4.7.4 Replacing the NFC PCB](#)

[4.7.5 Replacing the WLAN ANTENA SUB](#)

4.1 Notes on Replacing Parts

- The description in this manual may differ from the actual product due to design changes, etc.
- Unplug the power cord before starting work.
- Use a screwdriver that matches the size of the screw head.
- Assemble the parts in the reverse order of the disassembly procedure.
- When assembling parts, do not pinch cables or wires.
- Replace tapes and stickers with new ones depending on their condition.
- The following icons are used in this chapter.

 <p>Required tools Items to be prepared</p>	<p>Describe the tools required and items to be prepared for work.</p> <p>Note The number shown in the parentheses of the Phillips screwdriver is the size according to the JIS standard.</p>														
 <p>Number of screws used</p>	<p>Indicate the number of screws used. Refer to the following table for the type and standard of the screws.</p> <table border="1" data-bbox="544 1093 1343 1512"> <tr> <td>S1</td> <td>PAN HEAD SCREW M3 MEC</td> </tr> <tr> <td>S2</td> <td>BIND HEAD SCREW</td> </tr> <tr> <td>S3</td> <td>PAN HEAD P TIGHT SCREW</td> </tr> <tr> <td>S4</td> <td>PAN HEAD SCREW+SW+WS</td> </tr> <tr> <td>S5</td> <td>PAN HEAD P TIGHT SCREW</td> </tr> <tr> <td>S6</td> <td>PAN HEAD SCREW M2 MEC</td> </tr> <tr> <td>S7</td> <td>BIND P TIGHT</td> </tr> </table>	S1	PAN HEAD SCREW M3 MEC	S2	BIND HEAD SCREW	S3	PAN HEAD P TIGHT SCREW	S4	PAN HEAD SCREW+SW+WS	S5	PAN HEAD P TIGHT SCREW	S6	PAN HEAD SCREW M2 MEC	S7	BIND P TIGHT
S1	PAN HEAD SCREW M3 MEC														
S2	BIND HEAD SCREW														
S3	PAN HEAD P TIGHT SCREW														
S4	PAN HEAD SCREW+SW+WS														
S5	PAN HEAD P TIGHT SCREW														
S6	PAN HEAD SCREW M2 MEC														
S7	BIND P TIGHT														
 <p>Time required for replacement</p>	<p>Indicate the approximate period of time from when you start removing parts until when you finish assembling them.</p>														

- Remove the battery before starting disassembly.



4.2 EXPLODED VIEW

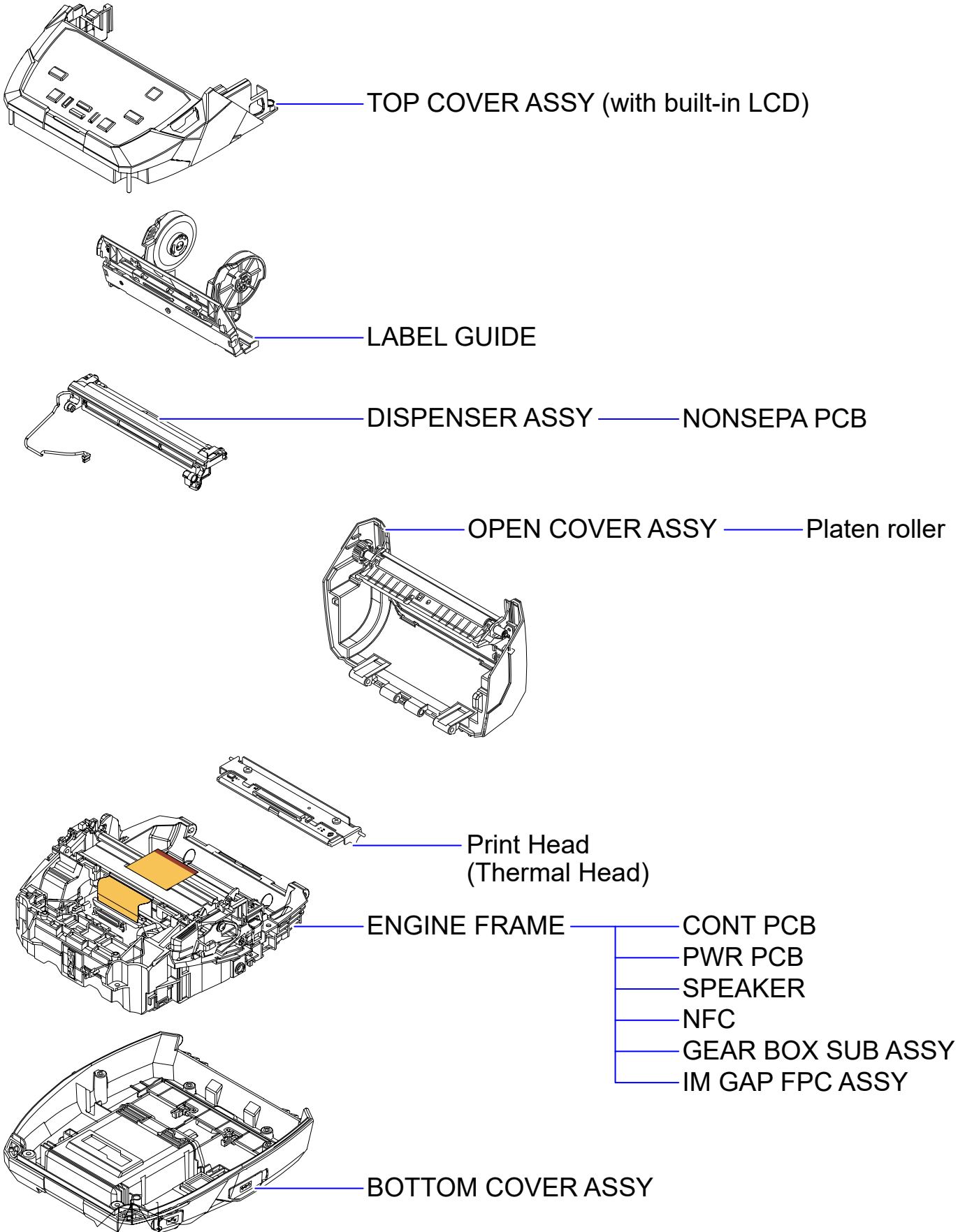

4.3 Case Cover

4.3.1 Replacing the TOP COVER ASSY

LCD MODULE



4 min.



Phillips screwdriver (#2)



S1×4

1 Remove four screws (S1).

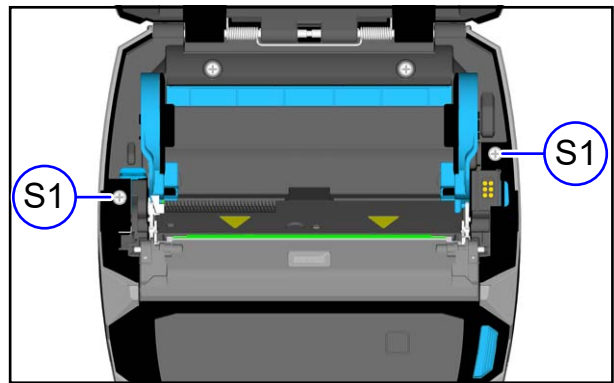
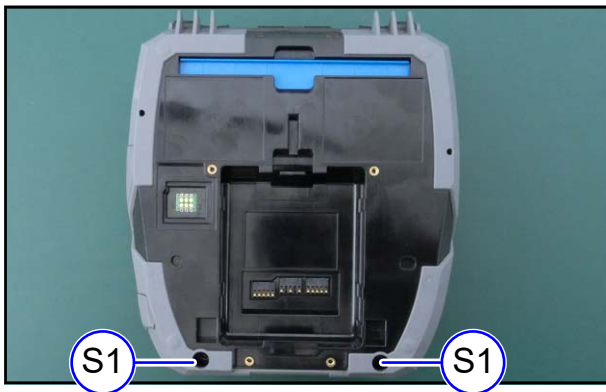

Notes on assembling

Make sure that the shafts of the TOP COVER ASSY are securely inserted into the case.



2 Remove the TOP COVER ASSY from the case and lift it.

NOTE

Since the TOP COVER ASSY is connected to the printer body with the LCD cable, remove it without applying a load to the LCD cable.

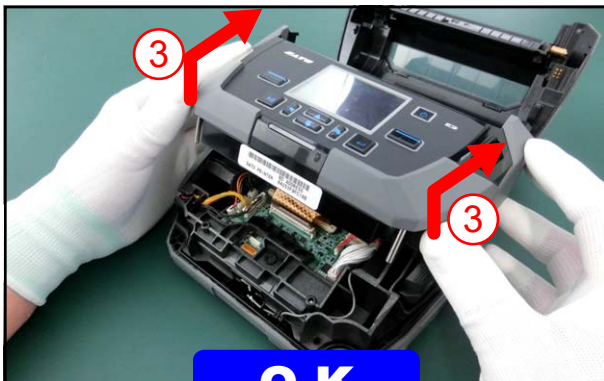
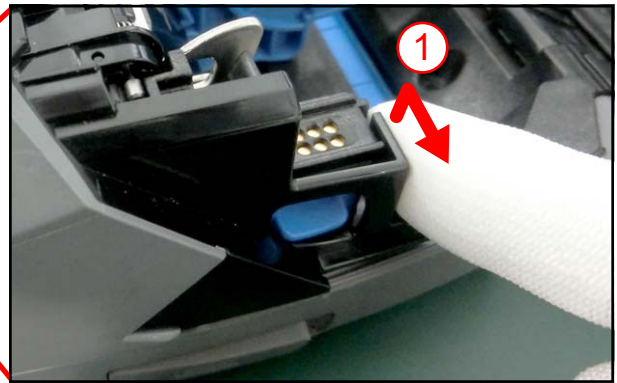

OK



NG

3 Release the connector lock, disconnect the FPC, and remove the TOP COVER ASSY (①).

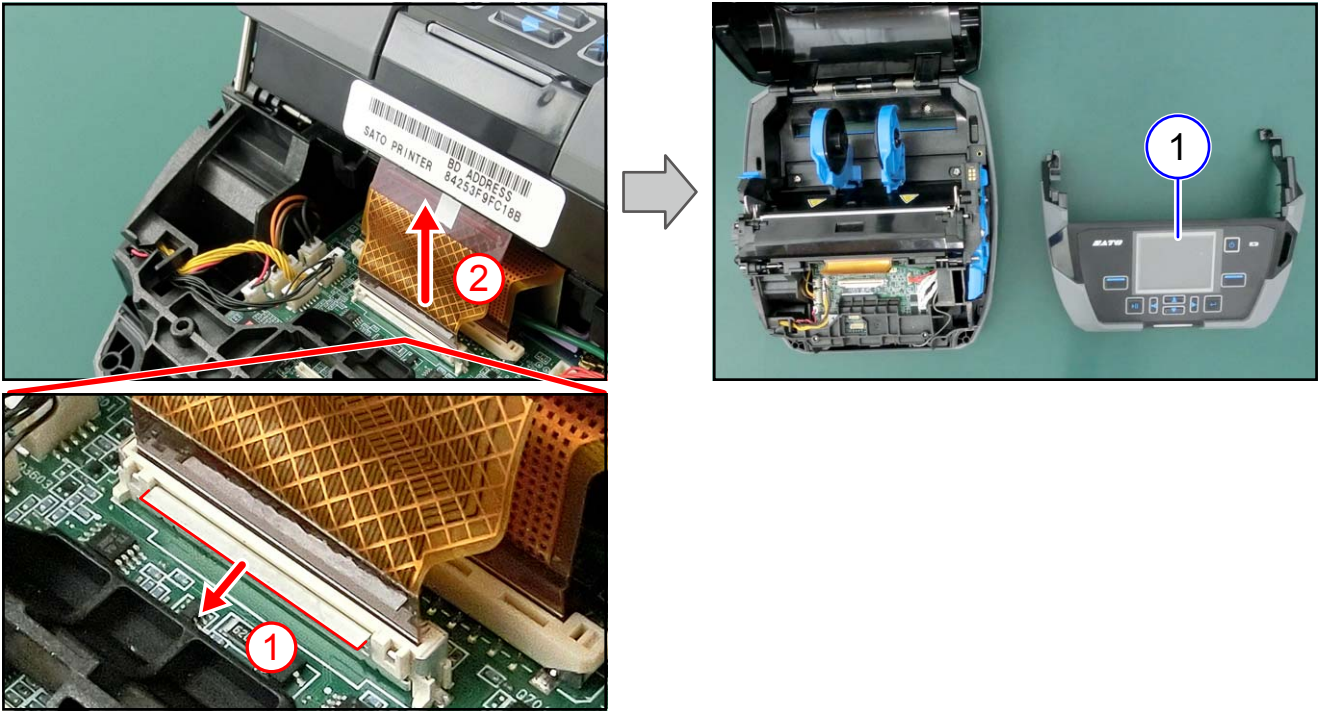

Notes on assembling

The connector lock is automatically locked when the FPC is inserted.

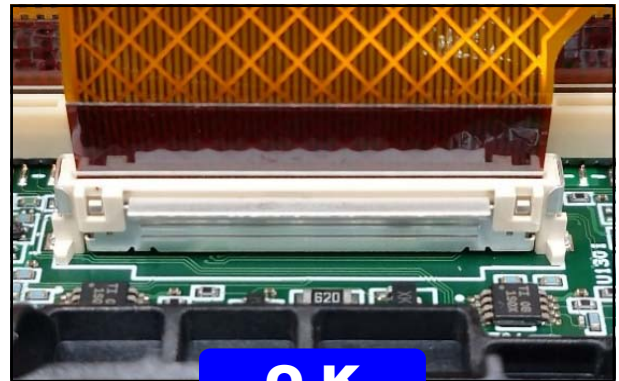

One side is not locked.

► **From here, assembling procedure**

4 Assemble the parts in the reverse order of the disassembly procedure.

4.3.2 Replacing the BOTTOM COVER ASSY



4 min.



Phillips screwdriver (#2)



S1×6

1 Remove six screws (S1).

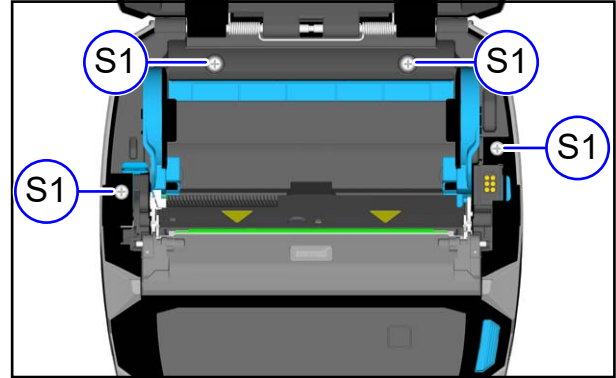
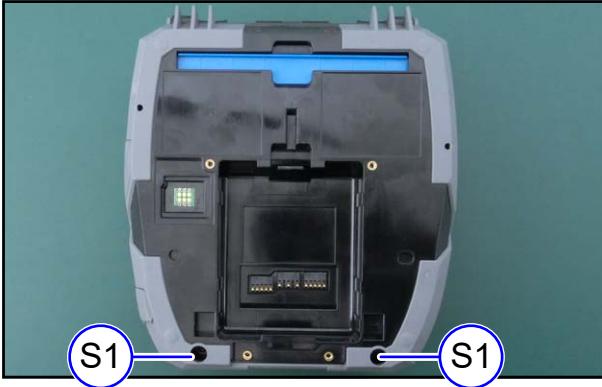

2 Remove the BOTTOM COVER ASSY (①).

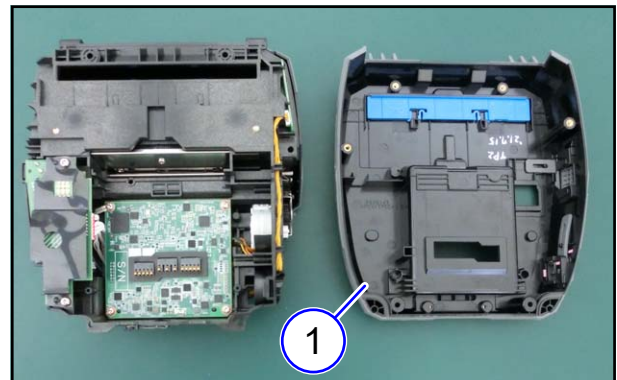

Details of the BOTTOM COVER ASSY

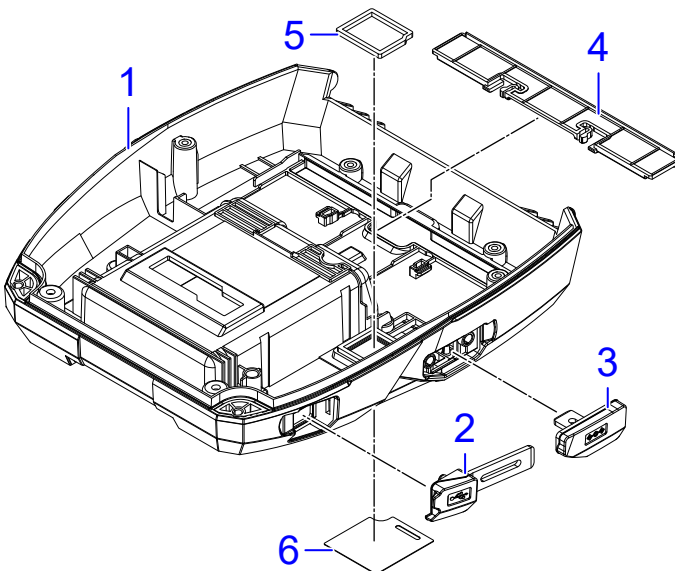

No.	DESCRIPTION
1	BOTTOM COVER(SILK)
2	USB COVER
3	DC COVER
4	FANFOLD COVER
5	CRADLE PACKING
6	CRADLE ACCESS SHEET

Notes on assembling No.2, 3

Securely insert the cover and make sure that it does not stick out from the case.

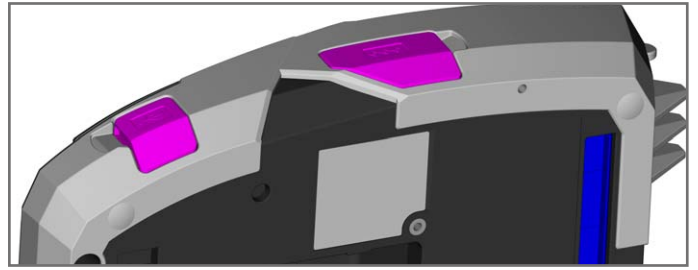
**Notes on assembling No.5**

Make sure that the CRADLE PACKING does not ride up on the edge of the case.

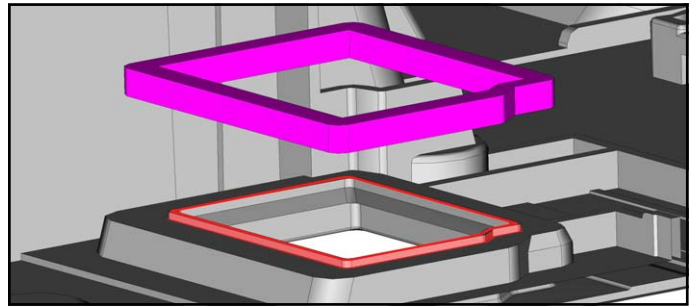
**Notes on assembling No.6**

Fix the sheet with double-sided adhesive tape, and make sure it does not stick out from the case.

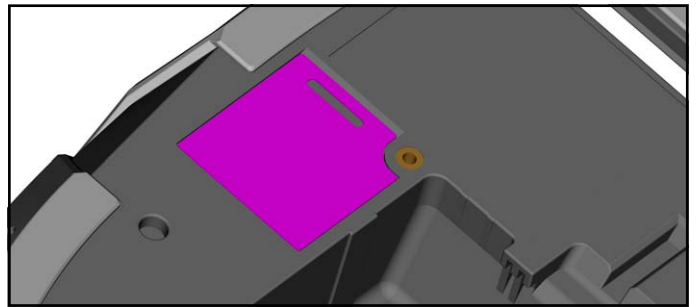
**► From here, assembling procedure**

- 3** Assemble the parts in the reverse order of the disassembly procedure.

4.3.3 Replacing the OPEN COVER ASSY

 8 min.

 Phillips screwdriver (#2)
Phillips screwdriver (#0)

 S1×6
S6×2

1 Remove the BOTTOM COVER ASSY (①).

Refer to [4.3.2 Replacing the BOTTOM COVER ASSY](#)

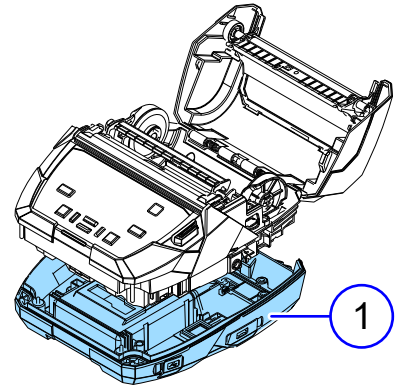

2 Pull out the HINGE SHAFT (②) and remove the OPEN COVER ASSY (③).

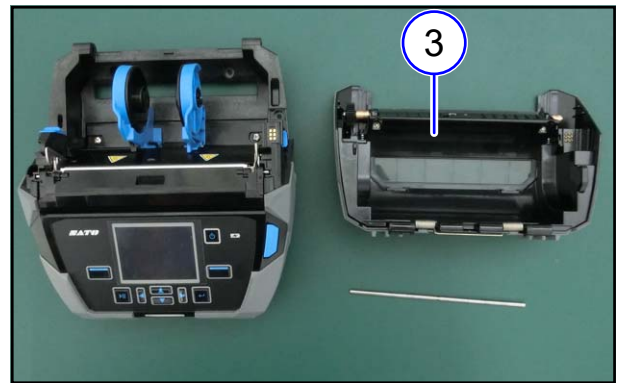
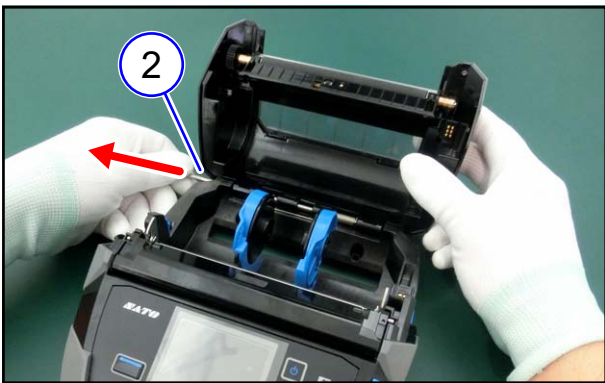

TIPS

The HINGE SPRING (④) may come off together.



Notes on assembling

(1) Put the spring into the case, paying attention to the direction.

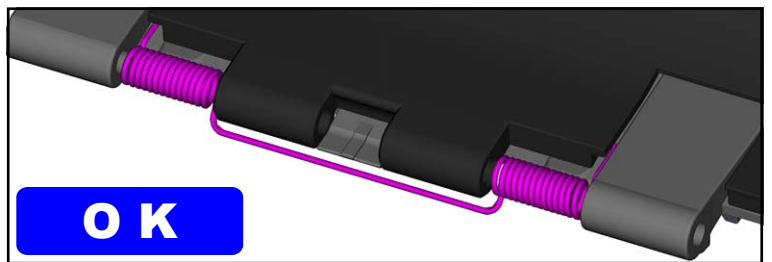
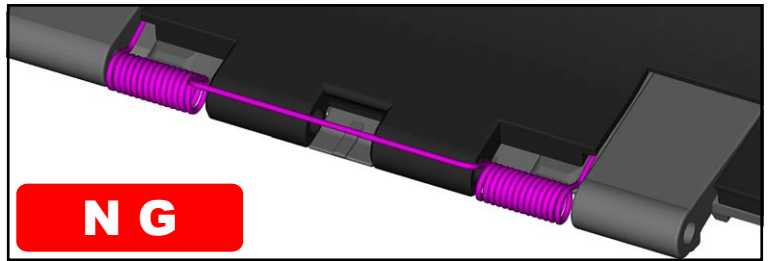
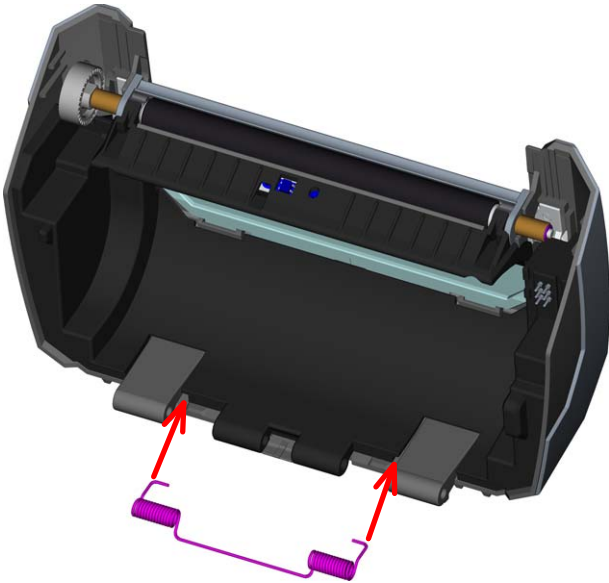

(2) Hang the shaft part of the spring on the case.

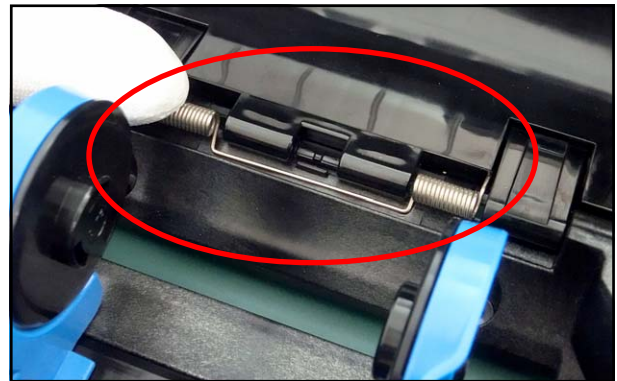
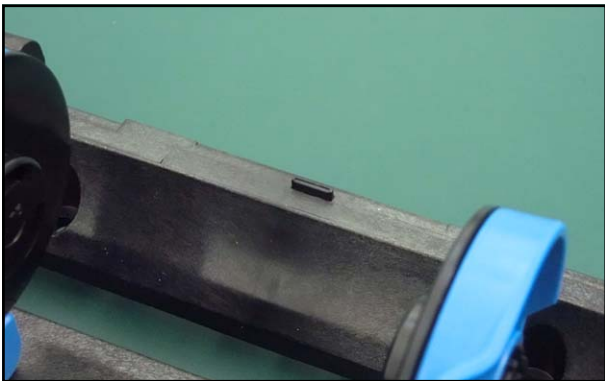

(3) Insert the concave part of the HINGE SHAFT into the convex part of the case.



3 Loosen two screws (S6) and remove the INNER COVER (②).

4 The HINGE SPRING (③) comes off together.

NOTE

Since the screw (S6) has a washer, it cannot be removed.

TIPS

Attach the HINGE SPRING when installing the OPEN COVER.

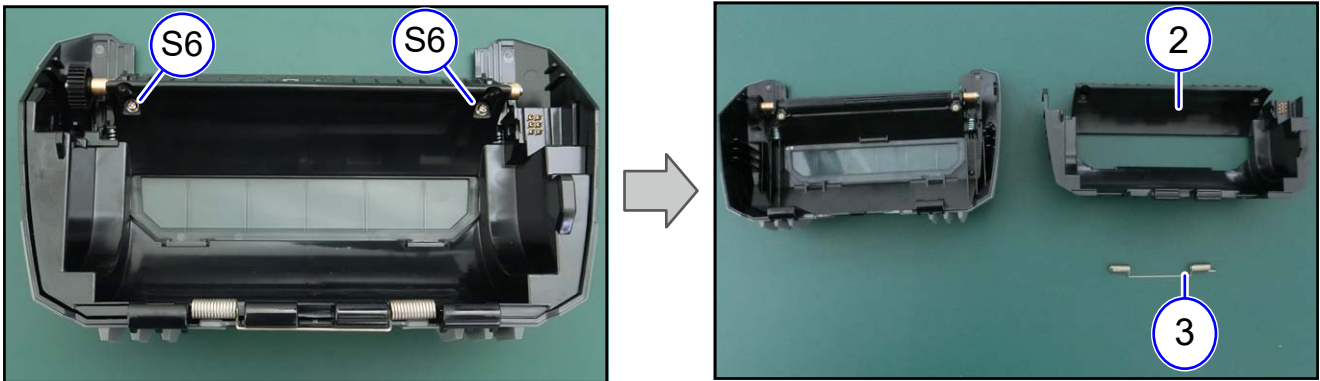

Details of the OPEN COVER

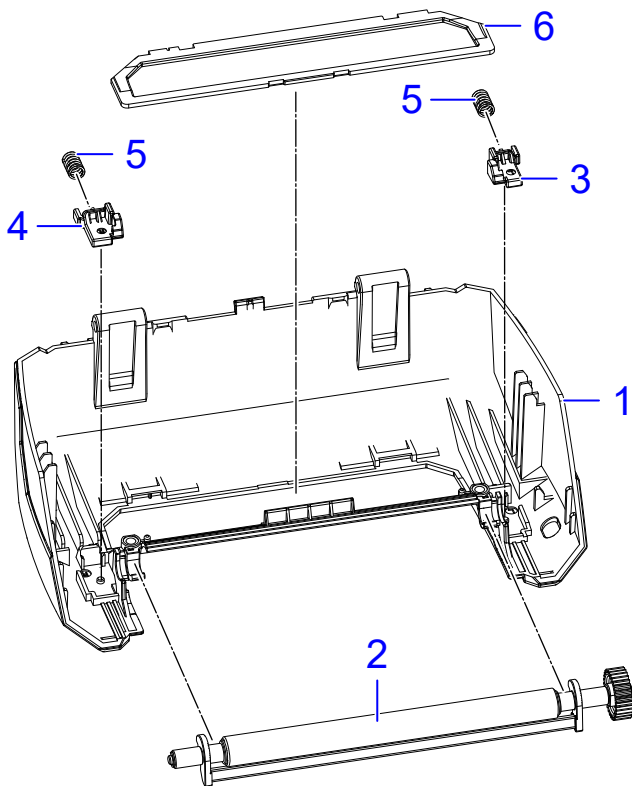

No.	DESCRIPTION
1	OPEN COVER
2	PLATEN ROLLER S/A
3	DIS NIP L
4	DIS NIP R
5	DIS NIP SPRING
6	WINDOW

► From here, assembling procedure

5 Assemble the parts in the reverse order of the disassembly procedure.

4.3.4 Replacing the DISPENSER ASSY



12 min.



Phillips screwdriver (#2)
Phillips screwdriver (#2)



S6×2
S5×1

1 Remove the TOP COVER ASSY (①).

Refer to [4.3.1 Replacing the TOP COVER ASSY](#)

2 Remove the BOTTOM COVER ASSY (②).

Refer to [4.3.2 Replacing the BOTTOM COVER ASSY](#)

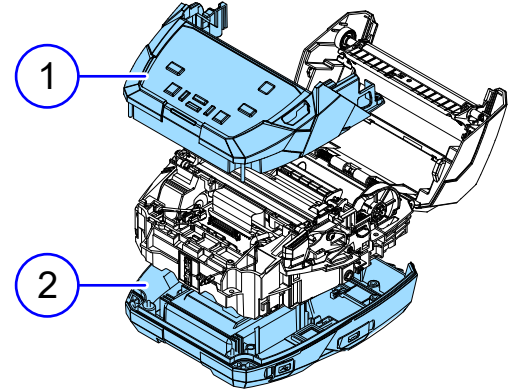

3 Disconnect one connector and remove the NONSEPA cable from the case.

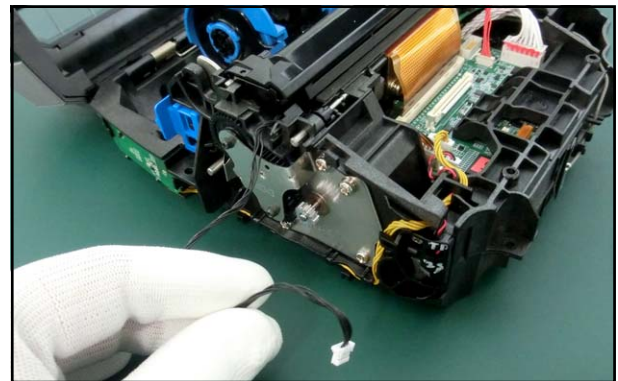
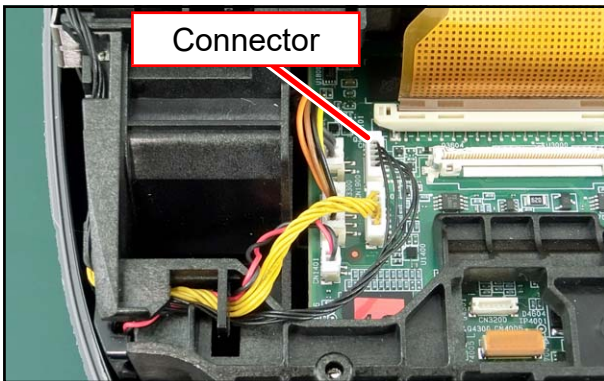

Notes on assembling

Pass the cable under the DIS COVER SHAFT (③).

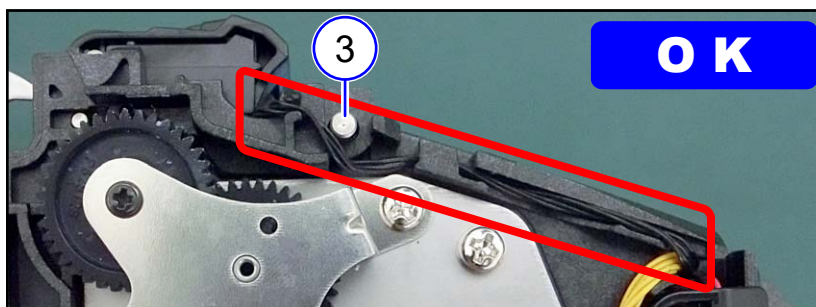

4 Lower the DIS OPEN LEVER (④) to set the printer to the Linerless state.

5 Remove one screw (S5).

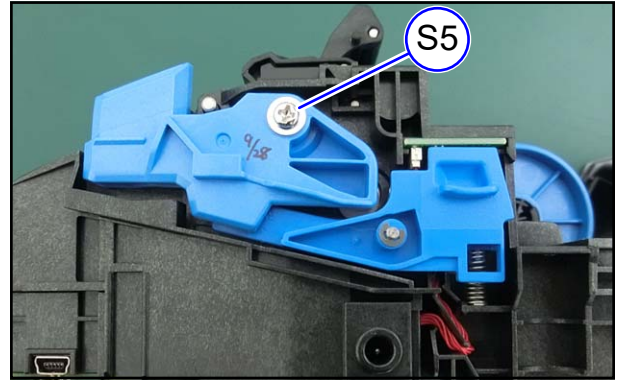
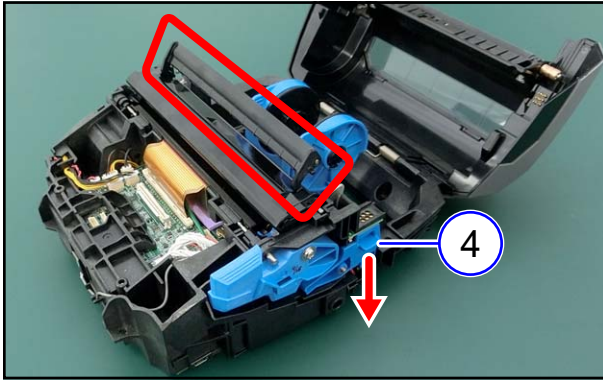

6 Remove the COVER OPEN LEVER (⑤) and OPEN LEVER BUSH (⑥).

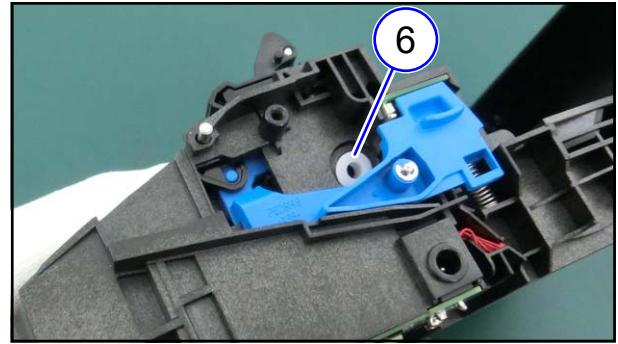
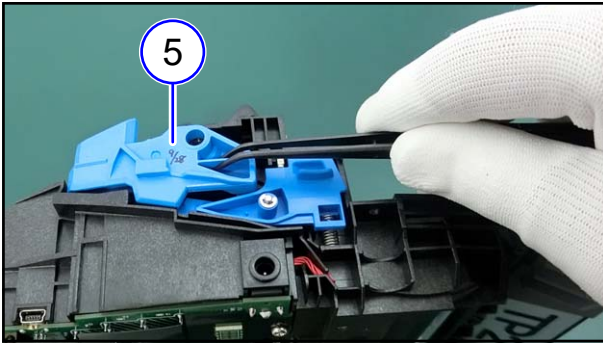

7 Remove two DIS COVER SHAFT (⑦).



Notes on assembling

Securely insert the DIS COVER SHAFT.

8 Remove the DISPENSER ASSY (⑧).

TIPS

Disengage the DISPENSER ASSY (hole) and DIS OPEN LEVER (shaft), and remove the DISPENSER ASSY.

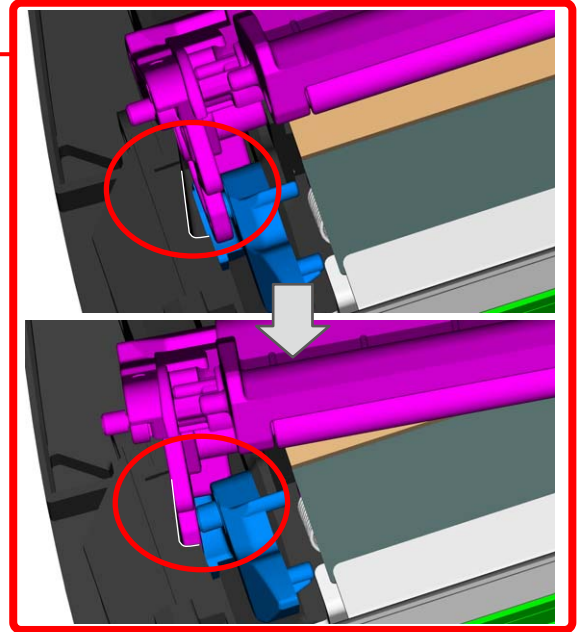
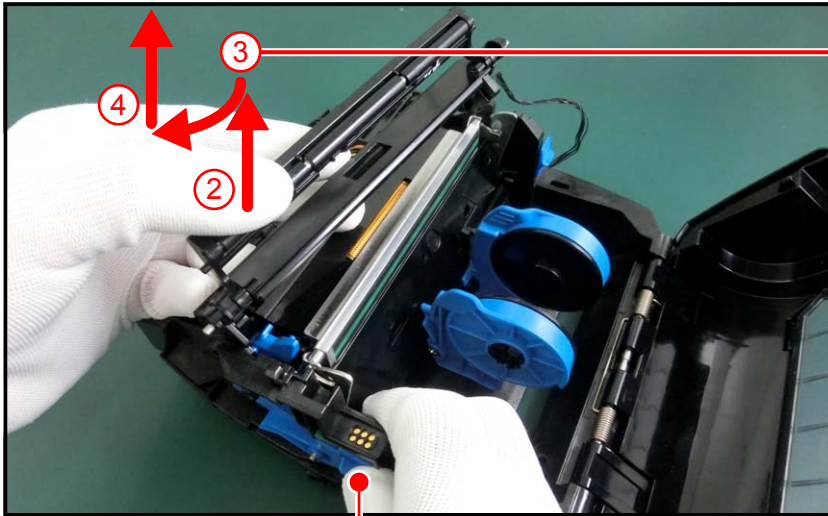
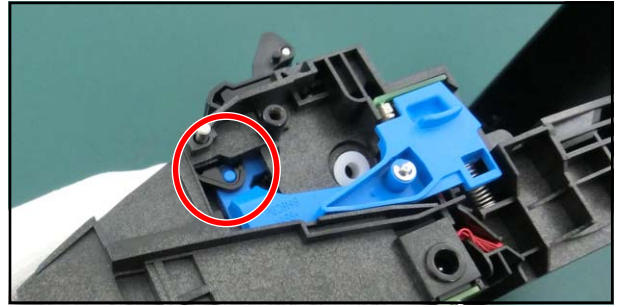

① Lower the DIS OPEN LEVER.

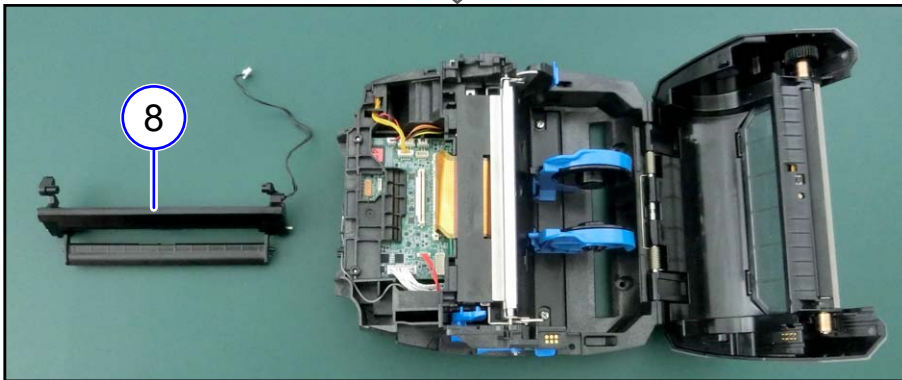

► **From here, assembling procedure**

9 Assemble the parts in the reverse order of the disassembly procedure.

4.4 Printing Section

4.4.1 Replacing the Print Head (Thermal Head)



4 min.



Isopropyl Alcohol (90% or higher)

NOTE

- Since the print head (thermal head) and its surroundings are hot after printing, wait until they cool down.
- Touching the edge of the print head (thermal head) with your bare hands may result in injury.

- 1 Press the cover open button (①) to open the top cover (②).
- 2 Press the dispenser roller release button (③) to release the dispenser unit (④).

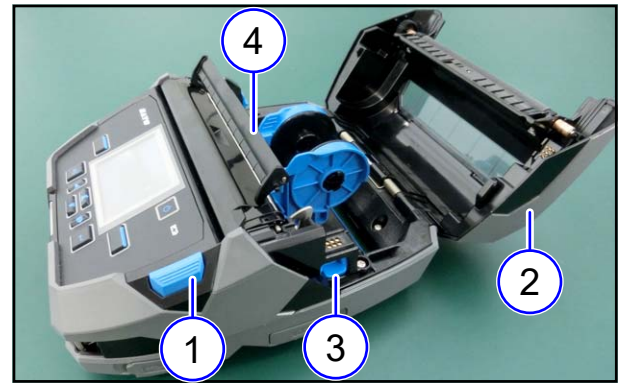

- 3 Push the dispenser unit (⑤) toward the front of the printer, and then remove the print head (thermal head) (⑥).

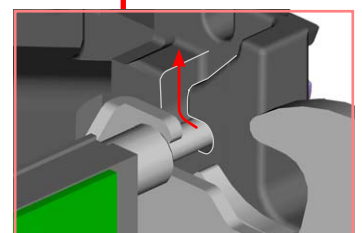
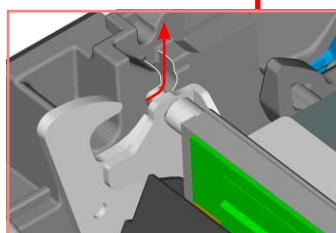
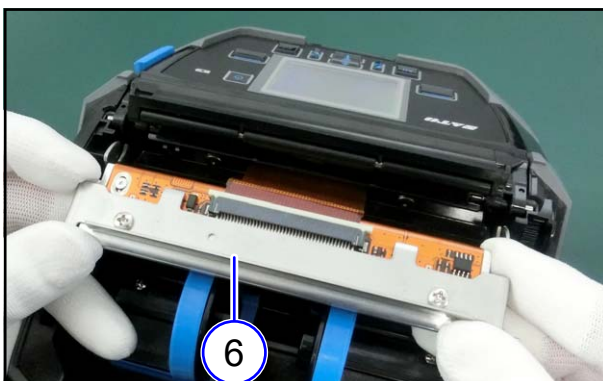
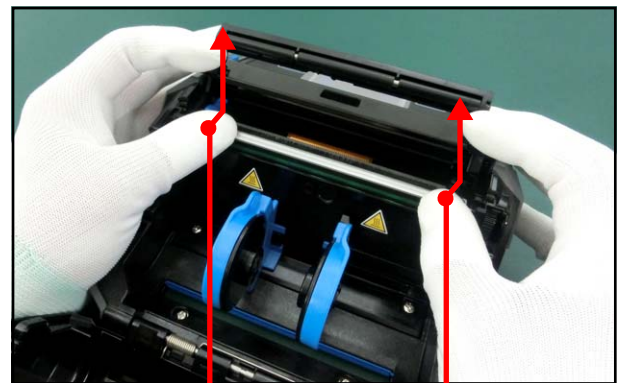
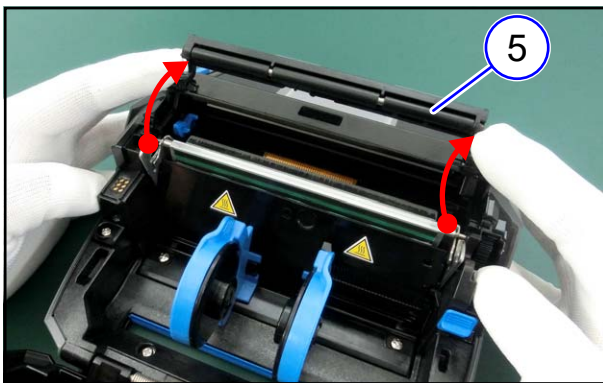

4 Release the connector lock (⑦) and remove the print head (thermal head) (⑧).

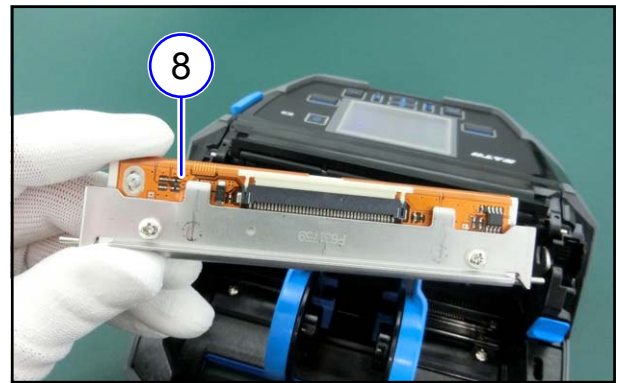
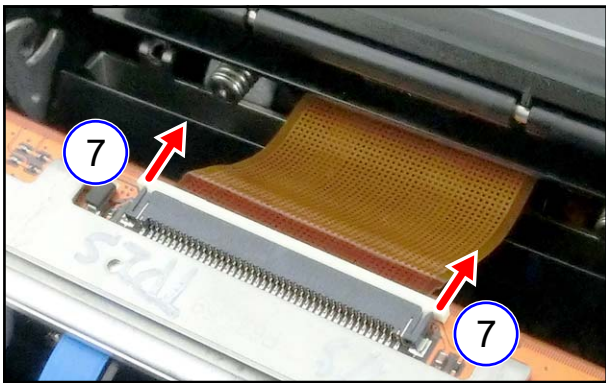

Notes on assembling

- Do not touch the heating element and terminals of the print head (thermal head).

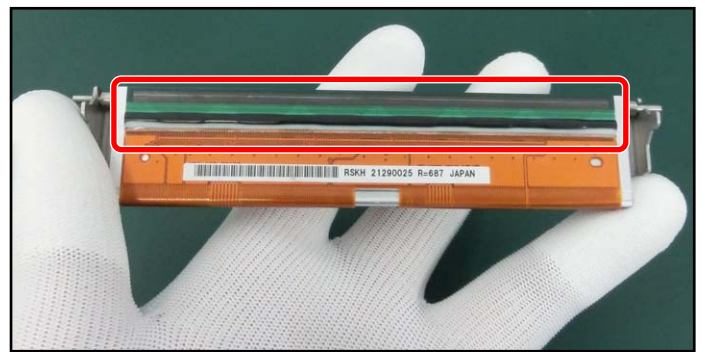

5 Securely insert the FPC into the connector of the print head (thermal head) and lock the connector.

Notes on assembling

- Make sure that the white line of the FPC is horizontal to the connector.

NG



OK

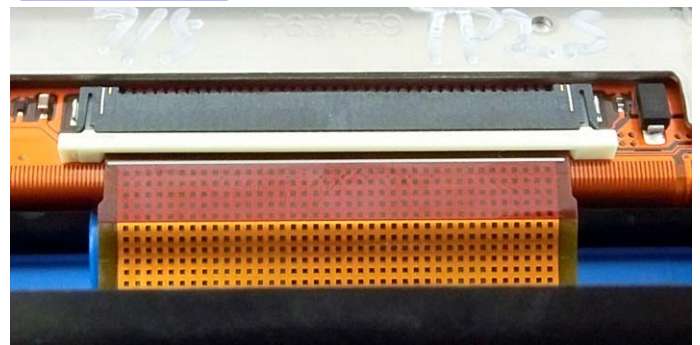

6 Clean the head part with IPA before installing the print head (thermal head).

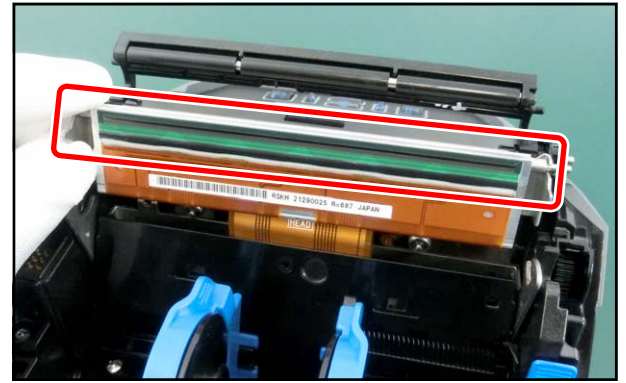

7 Push the dispenser unit (9) toward the front of the printer, and then install the print head (thermal head) (10).

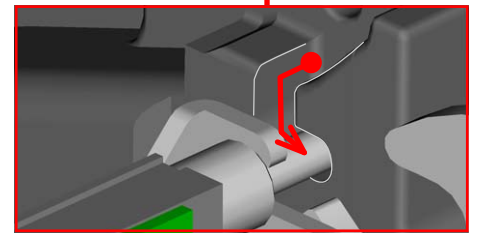
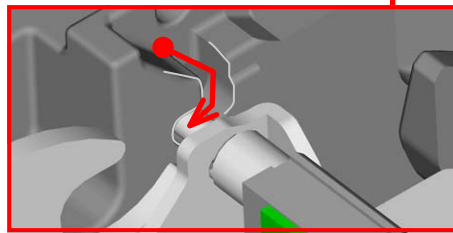
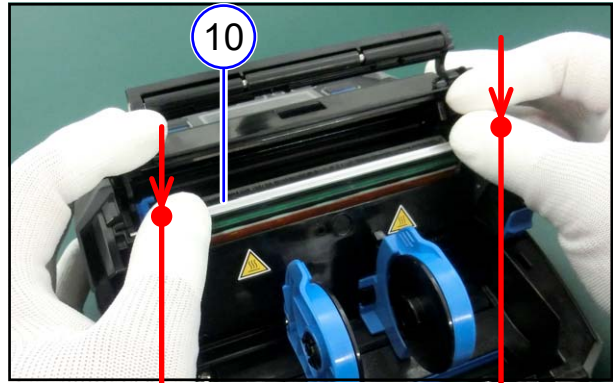
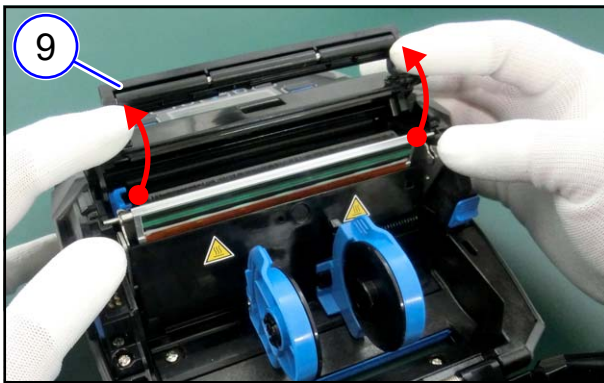

Notes on assembling

- Make sure that the HEAD LOCATE PIN (11) is securely inserted into the case, on both sides.

NG

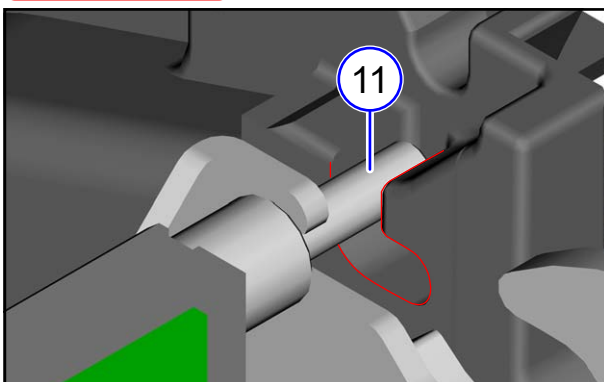

OK

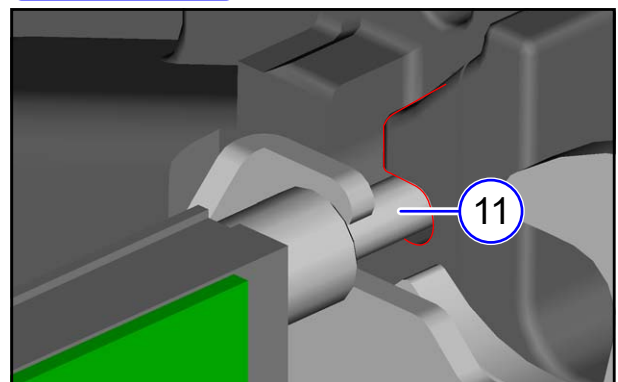

► From here, assembling procedure

8 Assemble the parts in the reverse order of the disassembly procedure.

4.5 Paper Transfer Section

4.5.1 Replacing the Platen Roller



4 min.



Phillips screwdriver (#0)



S6×2

- 1 Loosen two screws (S6).

TIPS

Since the screw (S6) has a washer, it cannot be removed.

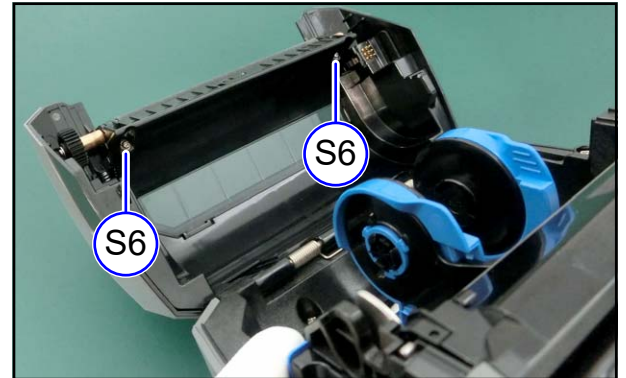

- 2 Tilt the inner cover (①) toward the front of the printer.

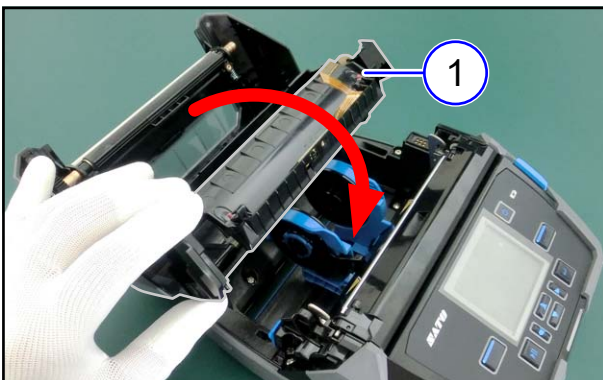

- 3 Remove the platen roller (②).

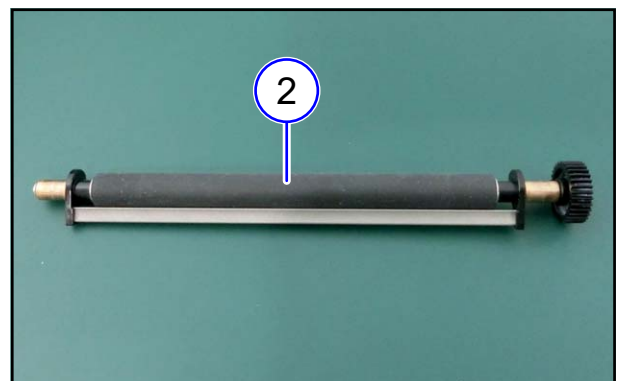
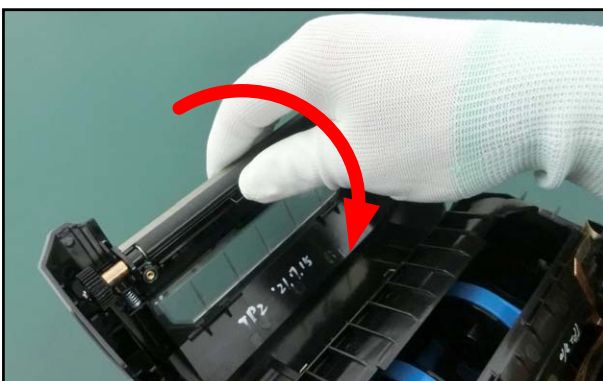

► From here, assembling procedure

- 4 Assemble the parts in the reverse order of the disassembly procedure.

4.5.2 Replacing the Label Guide



4 min.



Phillips screwdriver (#2)



S1×2

- 1 Remove two screws (S1).
- 2 Raise the media guide lock (①).

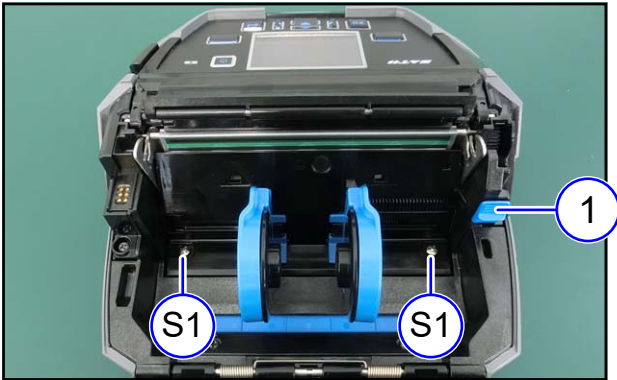

- 3 Remove the label guide.



► From here, assembling procedure

Tips on assembling

Place the LOCK UNIT RACK (②) under the lock bar (③) of the media guide lock.

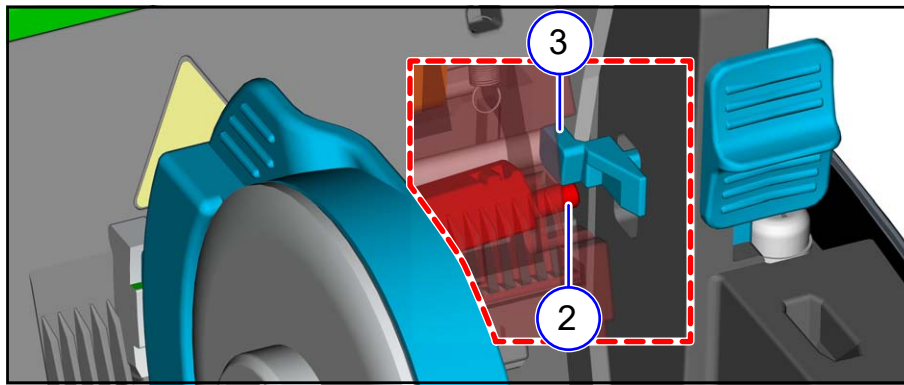
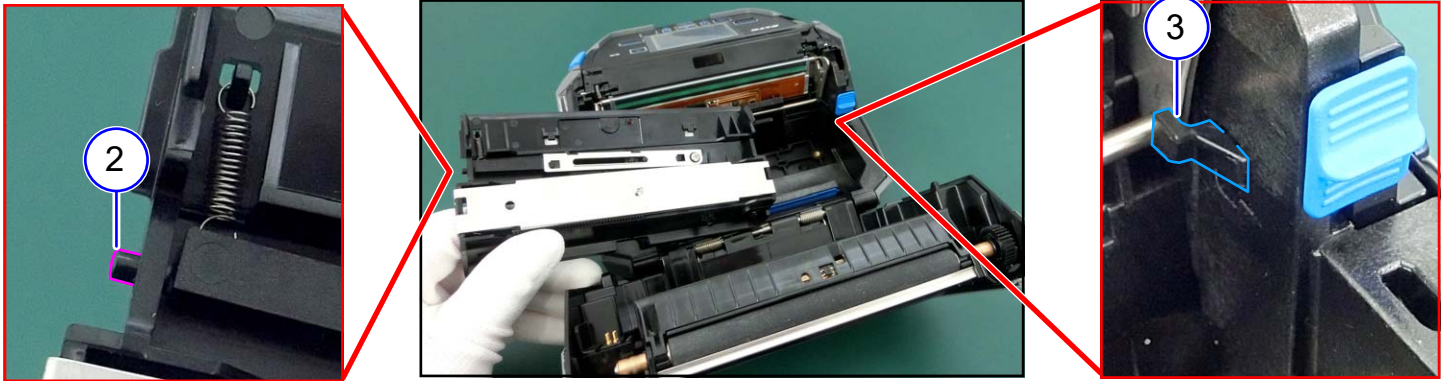

4 Install the label guide.

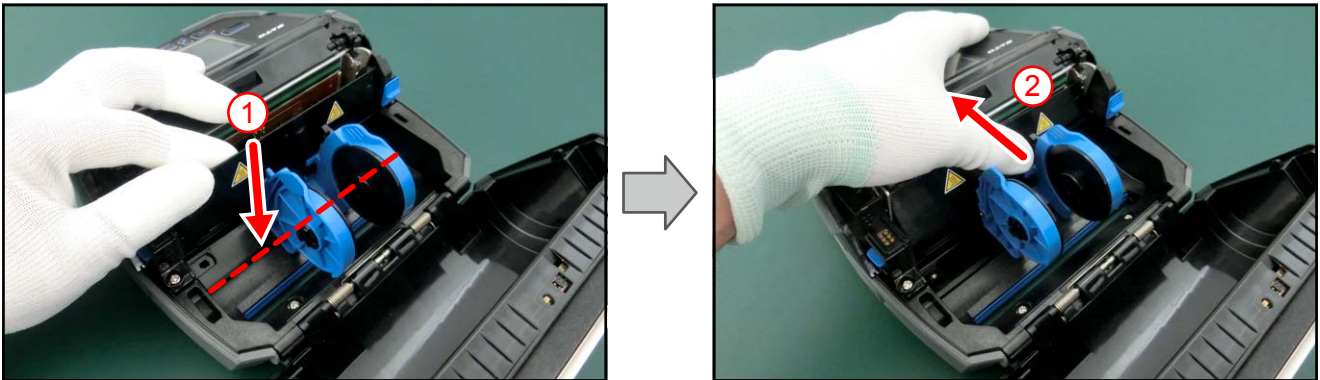

5 Tighten two screws (S1).

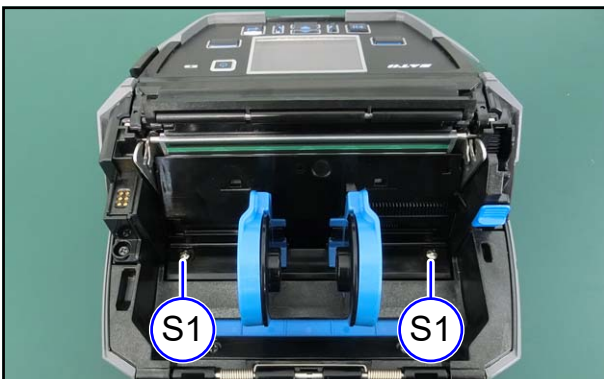

4.5.3 Replacing the GEAR BOX SUB ASSY



8 min.



Phillips screwdriver (#2)
Phillips screwdriver (#2)



S1×6
S3×3

1 Remove the TOP COVER ASSY (①).

Refer to [4.3.1 Replacing the TOP COVER ASSY](#)

2 Remove the BOTTOM COVER ASSY (②).

Refer to [4.3.2 Replacing the BOTTOM COVER ASSY](#)

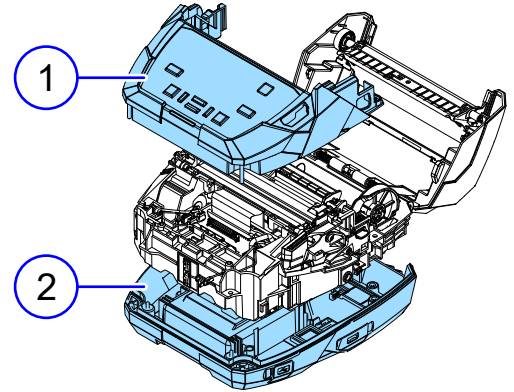

3 Disconnect two connectors.



4 Remove three screws (S3) and remove the GEAR BOX SUB ASSY (③).

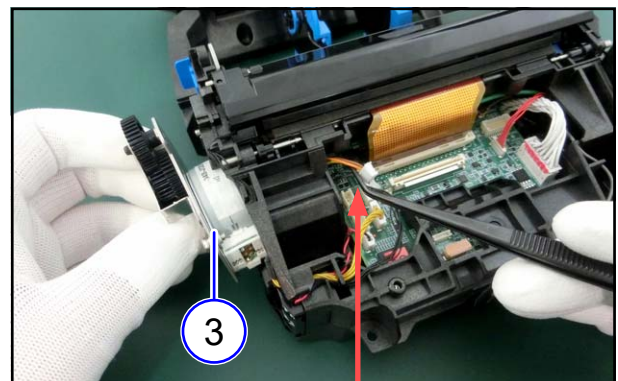
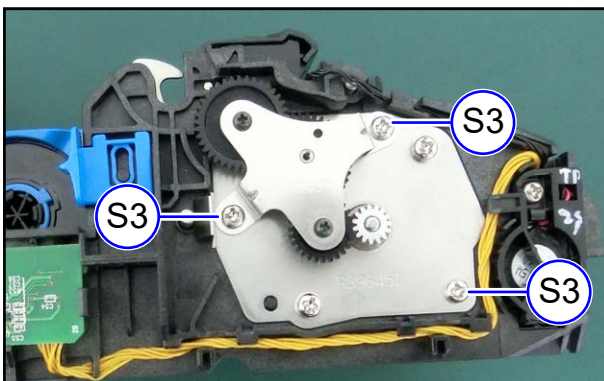

NOTE
Be careful that the connectors do not get caught on internal parts of the printer.

Notes on assembling

Pass the GEAR BOX SUB ASSY cable through the opening of the printer.

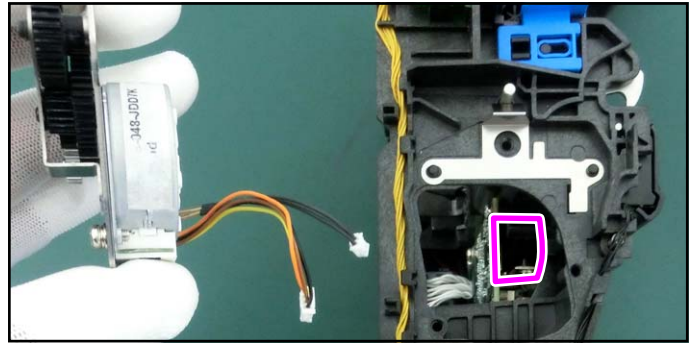
**► From here, assembling procedure**

- 5** Assemble the parts in the reverse order of the disassembly procedure.

4.6 Sensors

4.6.1 Replacing the IM GAP FPC ASSY

IM, Gap Sensor (Transmitter), Cover Open Sensor



16 min.



- Phillips screwdriver (#2)
- Phillips screwdriver (#0)
- Phillips screwdriver (#2)



- S1×6
- S6×2
- S3×1

1 Remove the INNER COVER (①).

Refer to [4.3.3 Replacing the OPEN COVER ASSY](#)

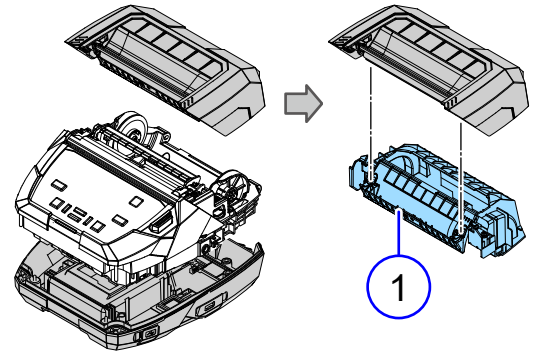

Details of the INNER COVER

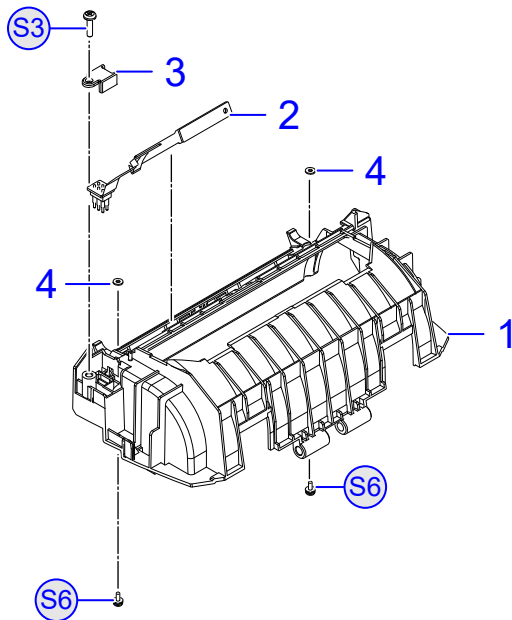

No.	DESCRIPTION
1	INNER COVER
2	PW4NX-IM GAP FPC ASSY-LF
3	FPC HOLDER
4	SET WASHER * Be careful not to lose it.

Notes on assembling IM GAP FPC ASSY

(1) Form the IM GAP FPC into shape.

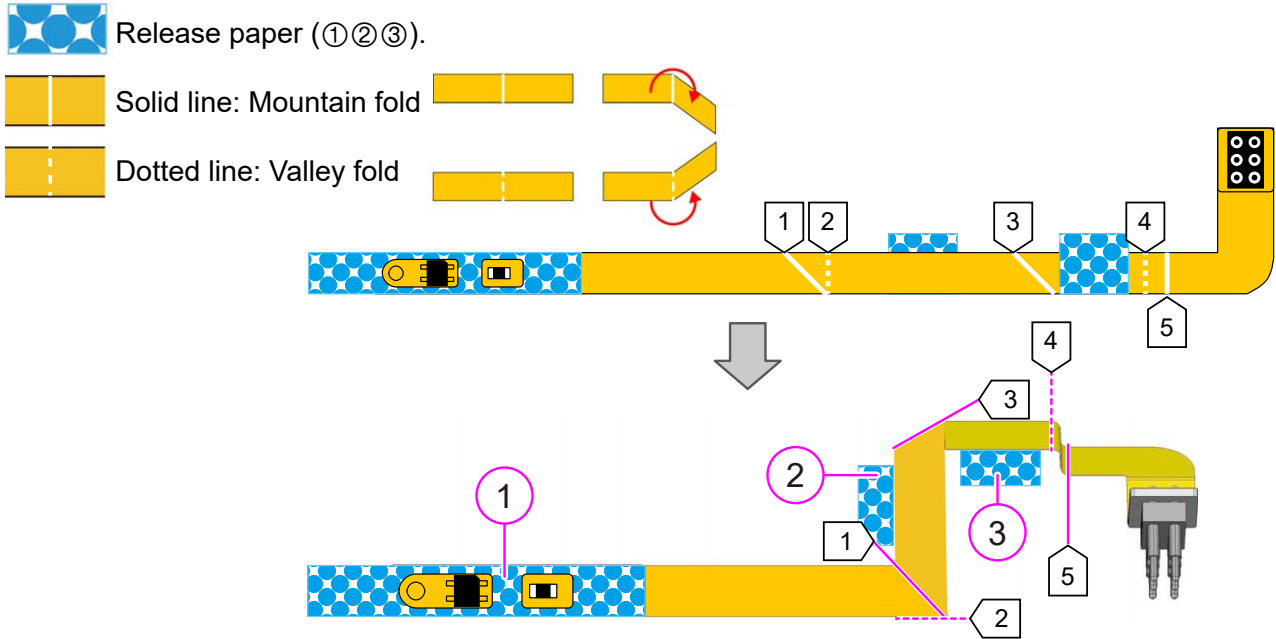

(2) Peel off the release paper ① and attach the sensor PCB to the FPC while aligning it to the positioning pin.

(3) Peel off the release paper ②③ and attach the FPC to the INNER CASE.

(4) Put the terminal part in the INNER CASE.

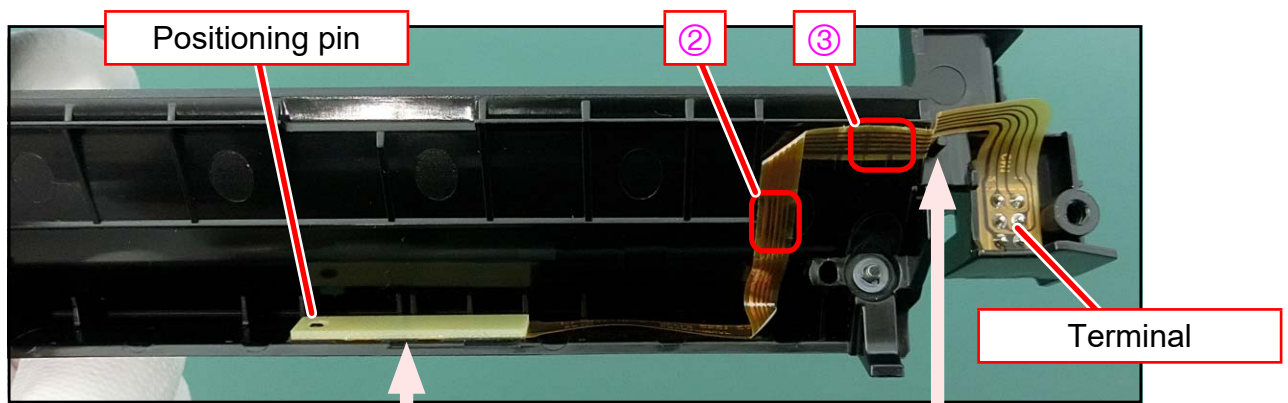

Notes on assembling

Make sure the IC and sensor do not touch the INNER CASE.

Notes on assembling

Pass the FPC between the protrusion and the INNER CASE.



► **From here, assembling procedure**

2 Assemble the parts in the reverse order of the disassembly procedure.

4.6.2 Replacing the DISP NONSEPA



10 min.



- Phillips screwdriver (#2)
- Phillips screwdriver (#0)
- Phillips screwdriver (#0)



- S1×6
- S6×1
- S7×2

1 Remove the DISPENSER ASSY (①).

Refer to [4.3.4 Replacing the DISPENSER ASSY](#)

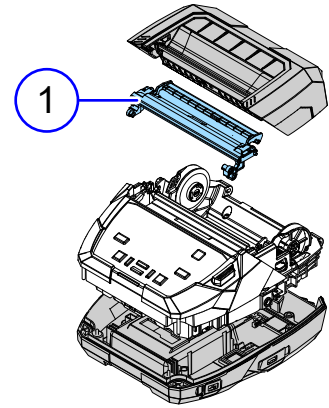

2 Remove two screws (S7).

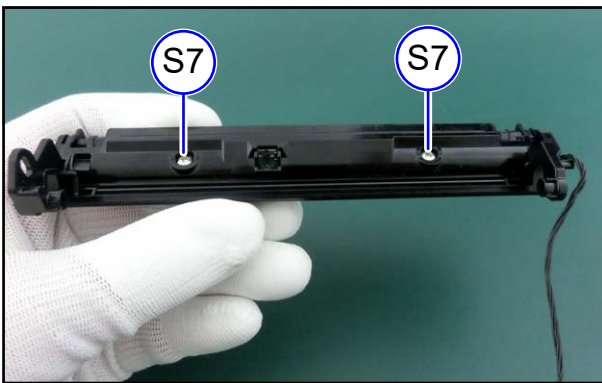

3 Remove two hooks (②) and remove the DIS UNDER COVER (③).

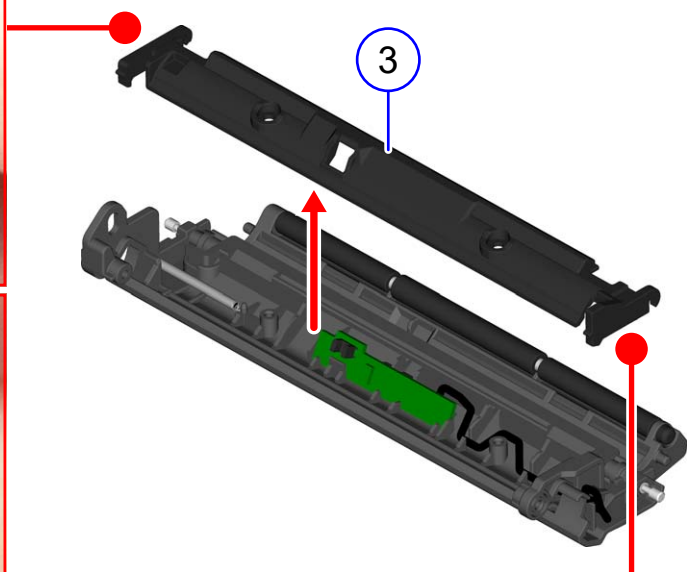
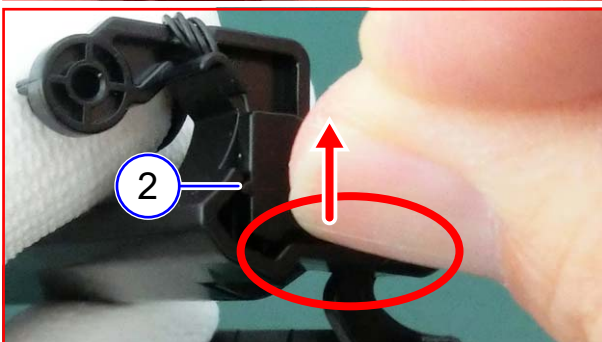

NOTE

Note that the DIS ARM SHAFT (④) may come off when the DIS UNDER COVER (③) is removed.

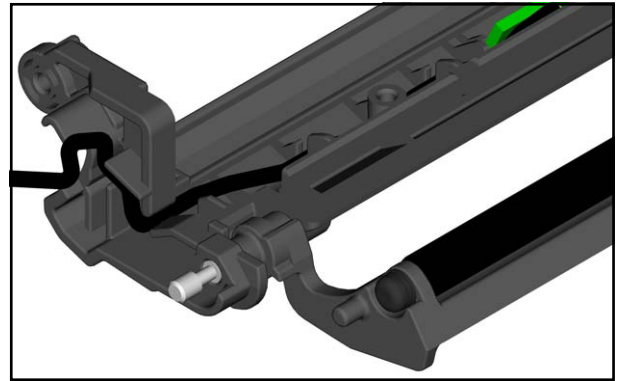
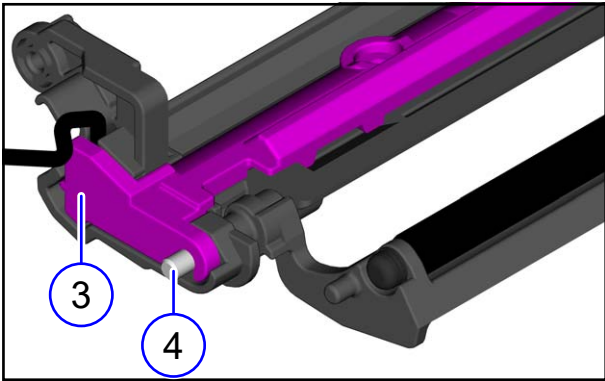

NOTE

If the DIS ARM SHAFT (④) comes off and the DIS ARM SPRING (⑤) is detached, refer to "Details of the DIS COVER UNIT" for assembling.

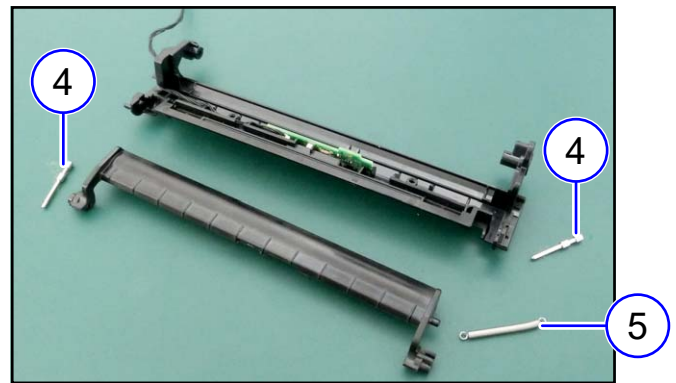

Notes on assembling

Make sure that the cable is not routed over the rib or screw hole.

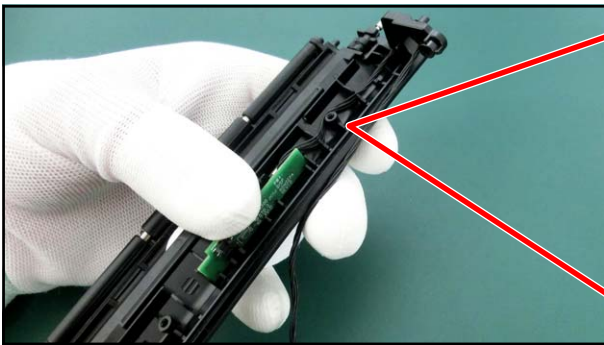

Notes on assembling

Make sure that the two hooks are securely inserted in place.

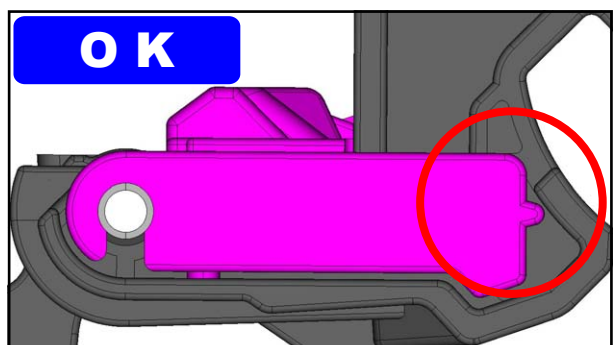
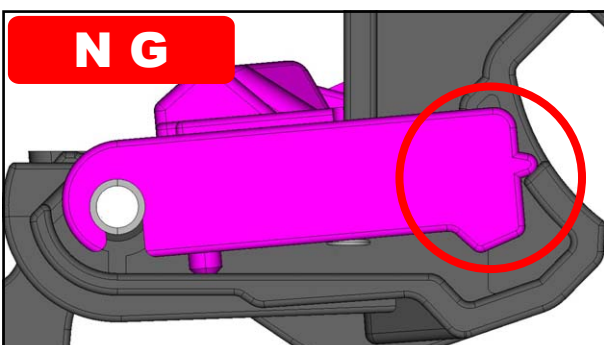

Details of the DIS COVER UNIT

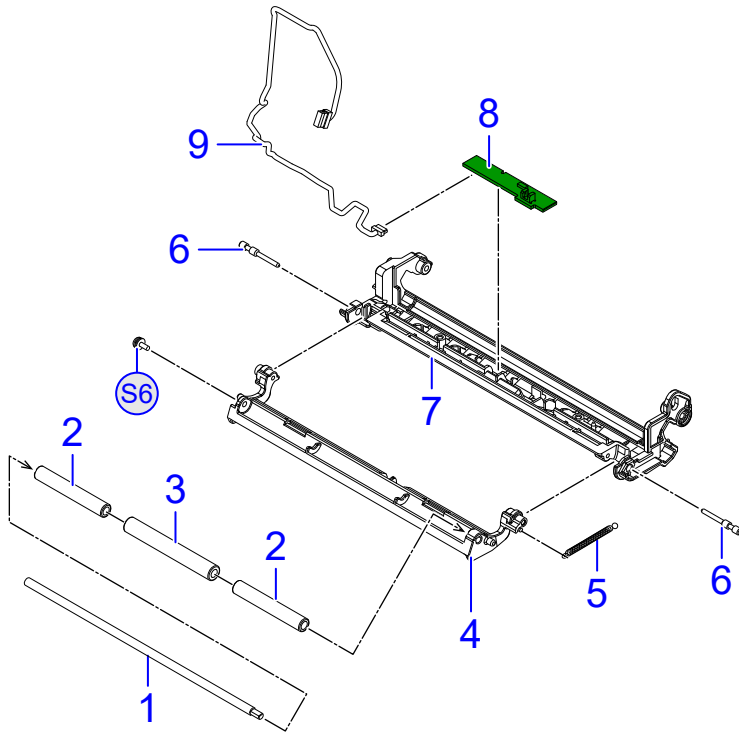

No.	DESCRIPTION
1	DIS ROLLER SHAFT
2	DIS ROLLER SIDE
3	DIS ROLLER CENTER
4	DIS ARM
5	DIS ARM SPRING
6	DIS ARM SHAFT
7	DIS COVER
8	PW4NX-DISP NONSEPA PCB ASSY-LF
9	DISP NONSEPA CABLE SET-LF

● Assembly procedure

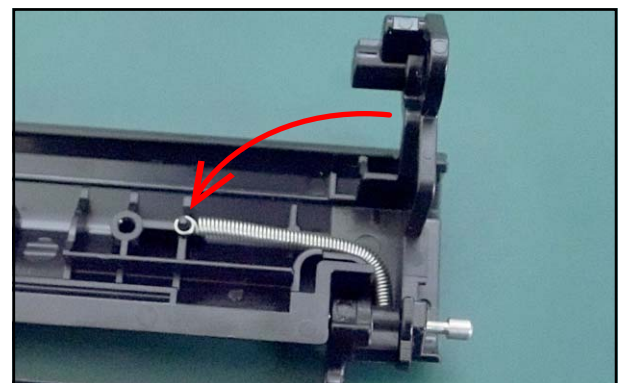
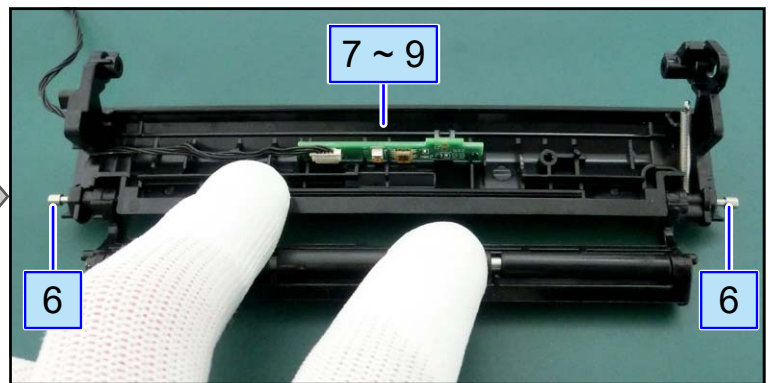
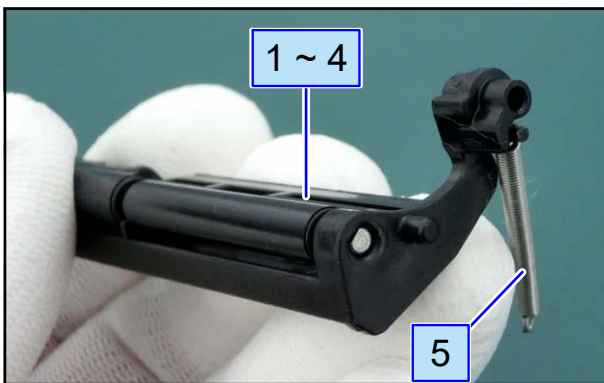

4 Remove the DISP NONSEPA PCB (⑥).

5 Disconnect the connector (⑦).

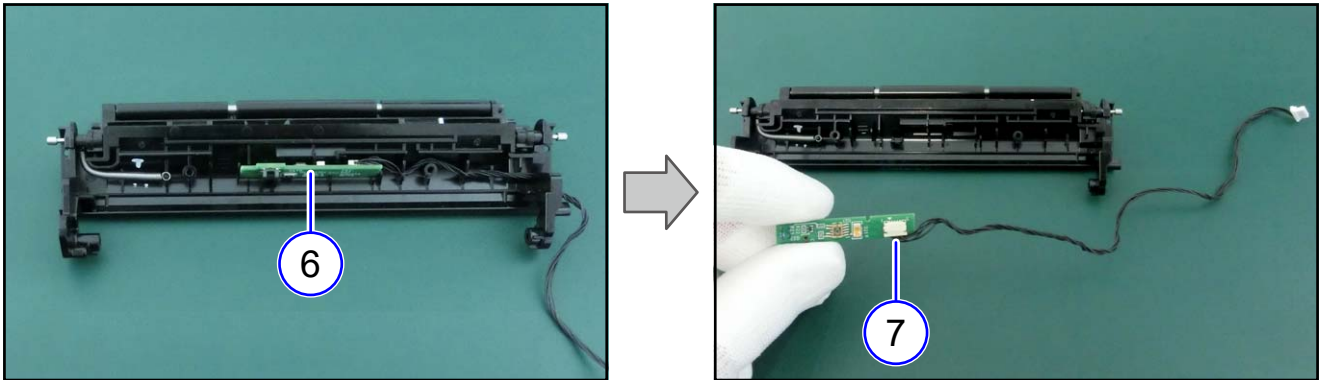

Notes on assembling

Route the cable as shown.

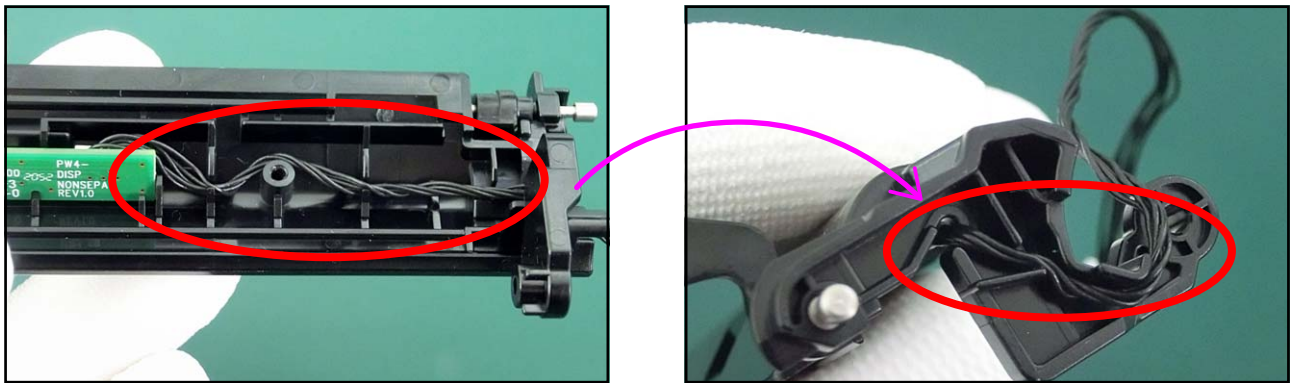

► From here, assembling procedure

6 Assemble the parts in the reverse order of the disassembly procedure.

4.6.3 Replacing the IM GAP RELAY



12 min.



Phillips screwdriver (#2)
Phillips screwdriver (#2)
Phillips screwdriver (#2)



S1×6
S3×2
S5×1

1 Remove the DISPENSER ASSY (①).

Refer to [4.3.4 Replacing the DISPENSER ASSY](#)

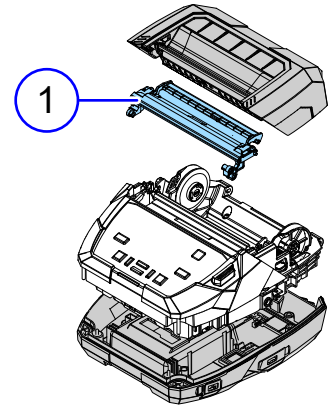

2 Remove the E SNAP RING (②) and pull out the LATCH SHAFT (③).

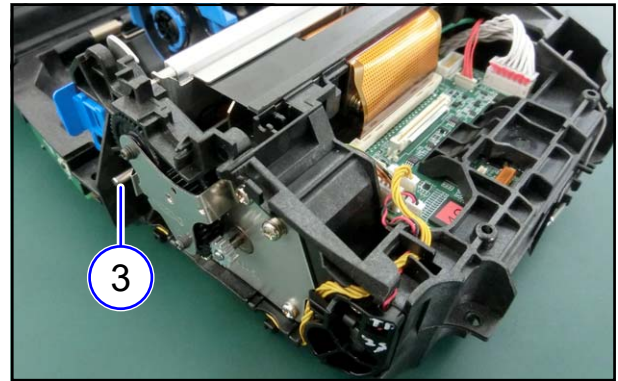
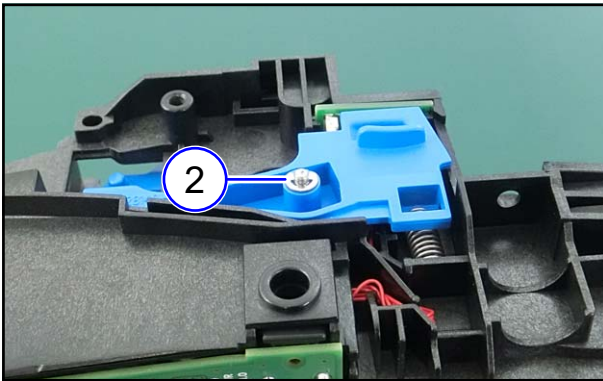

3 Remove the DIS LEVER SPRING (④).

4 Remove the DIS OPEN LEVER (⑤).

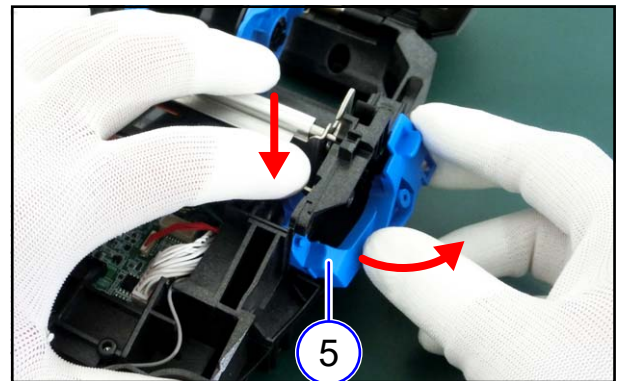
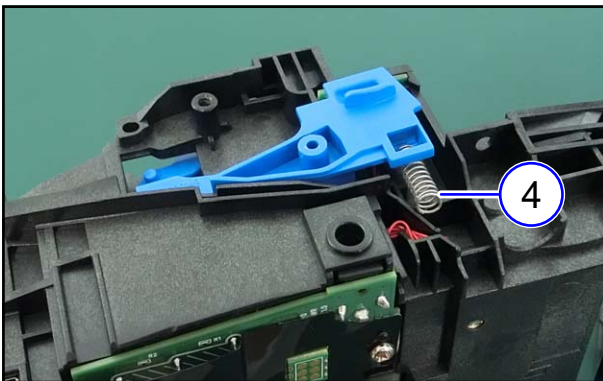

5 Remove the IM GAP RELAY (⑥).

6 Disconnect the connector (⑦).

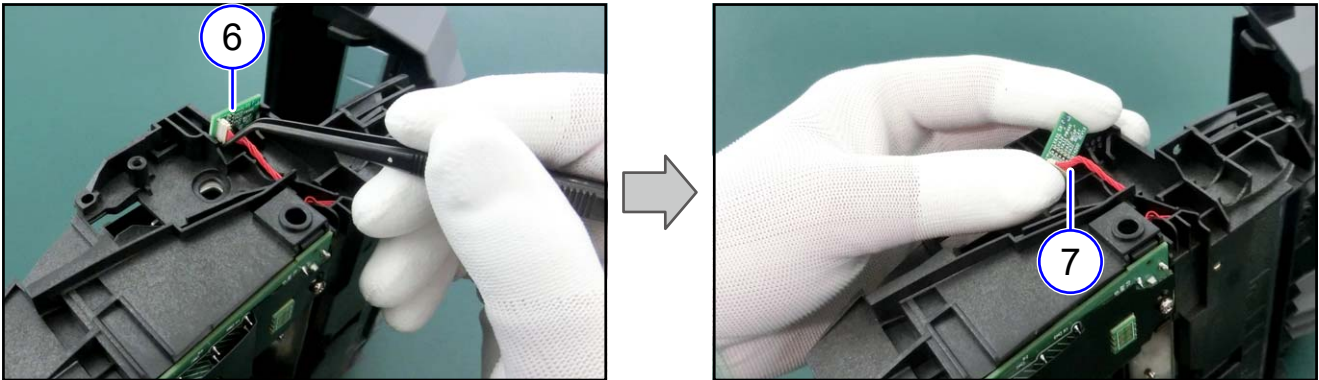

7 If you replace only the IM GAP RELAY PCB, no further steps are required. Assemble the removed parts in the reverse order of the disassembly procedure.

► **From here, IM GAP RELAY CABLE replacement procedure**

8 Disconnect the two connectors.

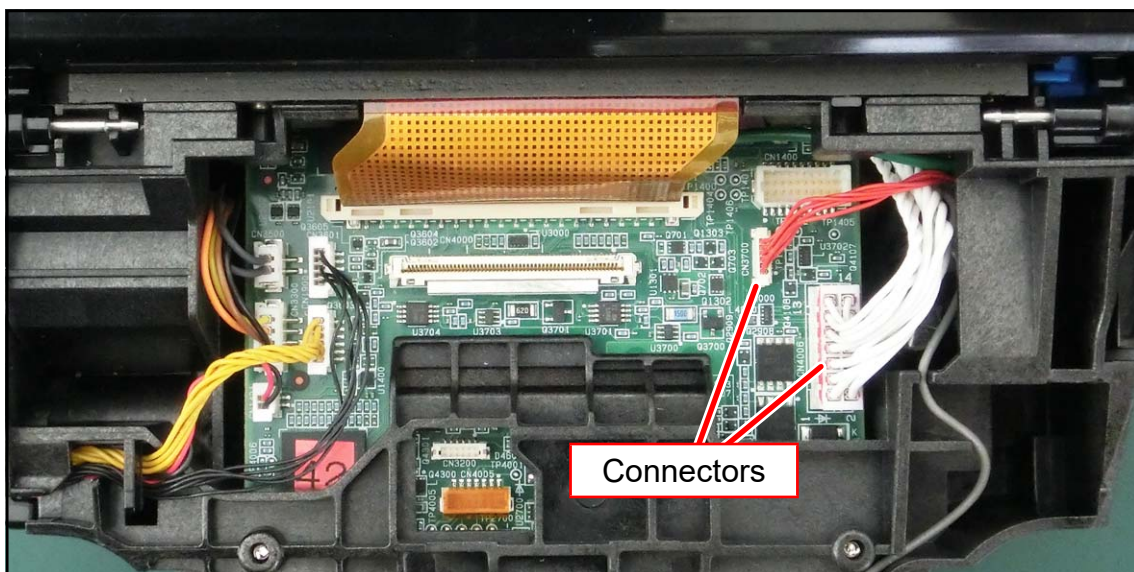

9 Remove two screws (S3) and remove the PWR PCB (⑧).

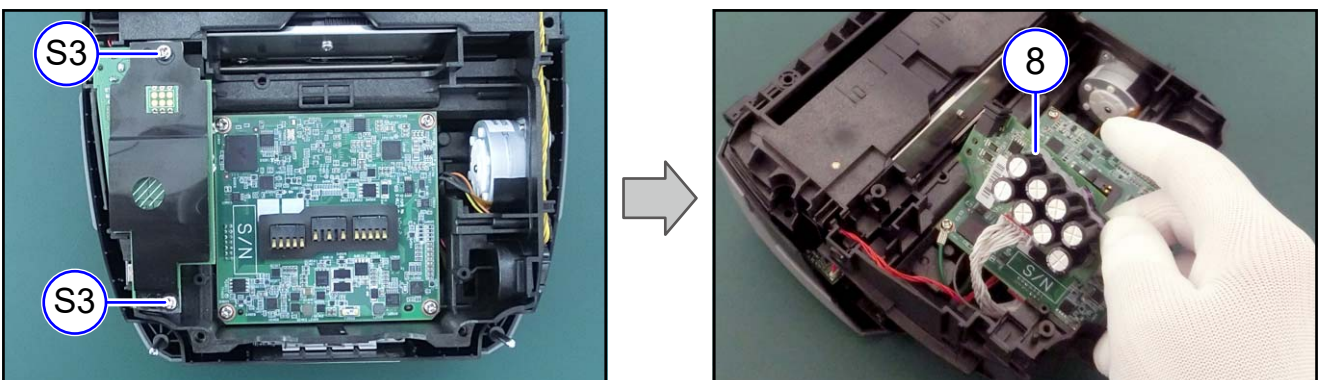

10 Remove the IM GAP RELAY CABLE (⑨) from the case.

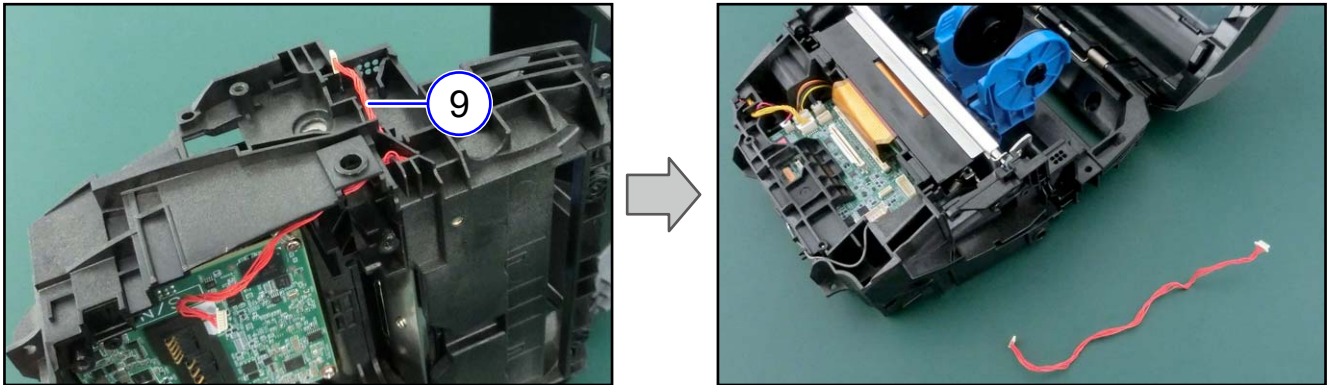

► **From here, assembling procedure from here**

11 Connect the cable to the IM GAP RELAY PCB (⑩) and then assemble the IM GAP RELAY PCB into the printer.

12 Route the cable to the printer.

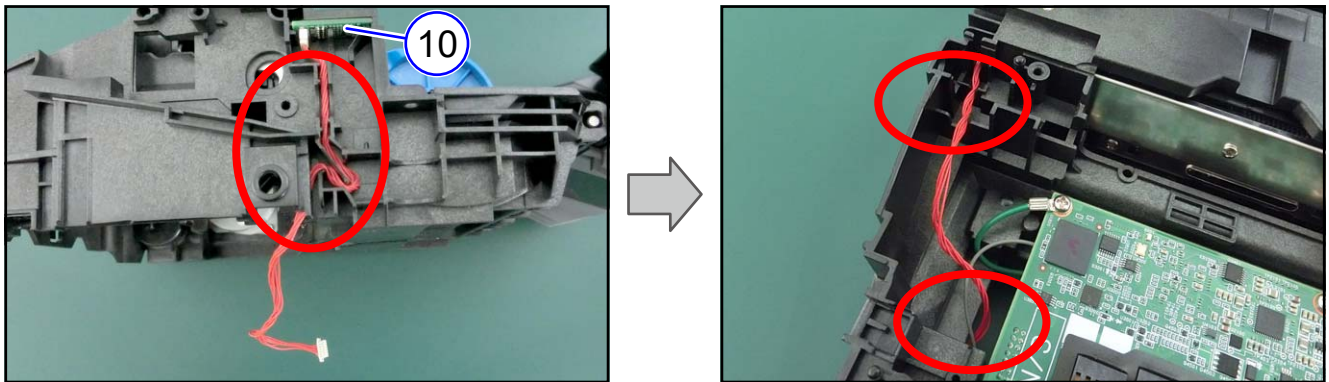

13 Reverse the procedure from step 9.

4.6.4 Replacing the HEAD FPC ASSY

Gap Sensor (Receiver)



20 min.



- Phillips screwdriver (#2)
- Phillips screwdriver (#2)
- Phillips screwdriver (#2)



- S1×6
- S4×2
- S5×1

1 Remove the Print Head (①).

Refer to [4.4.1 Replacing the Print Head \(Thermal Head\)](#)

2 Remove the DISPENSER ASSY (②).

Refer to [4.3.4 Replacing the DISPENSER ASSY](#)

3 Remove the Label Guide (③).

Refer to [4.5.2 Replacing the Label Guide](#)

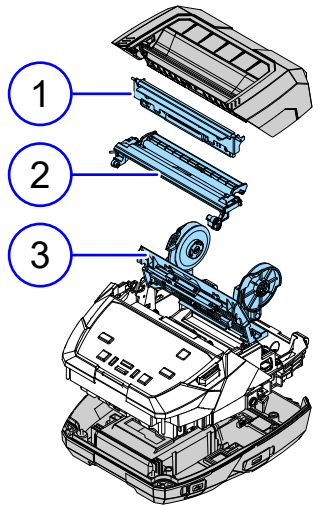

4 Remove the HEAD COVER SHEET (④).

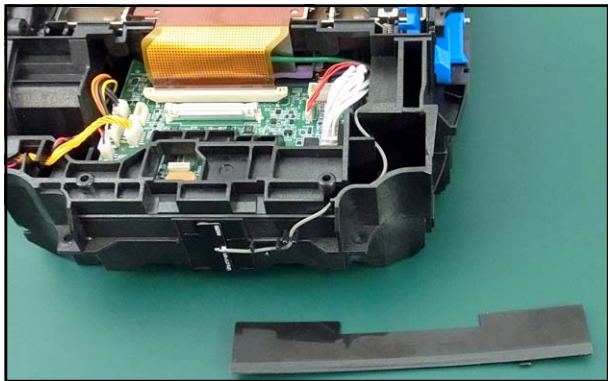
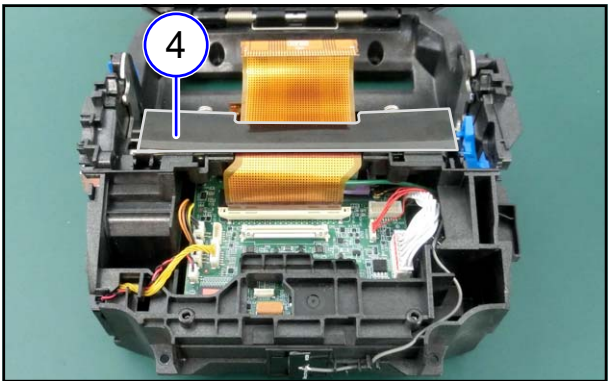

Details of the HEAD COVER SHEET

No.	DESCRIPTION
1	HEAD COVER SHEET
2	HEAD PACKING

Notes on assembling

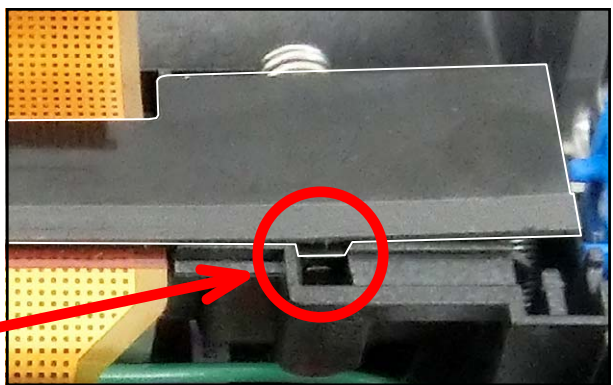
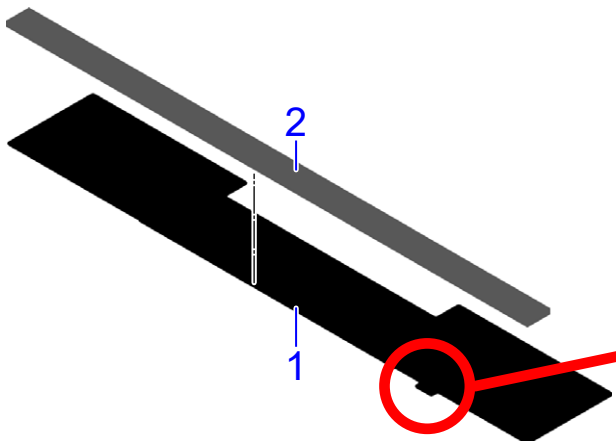

5 Remove the E SNAP RING (⑤) and pull out the LATCH SHAFT (⑥).

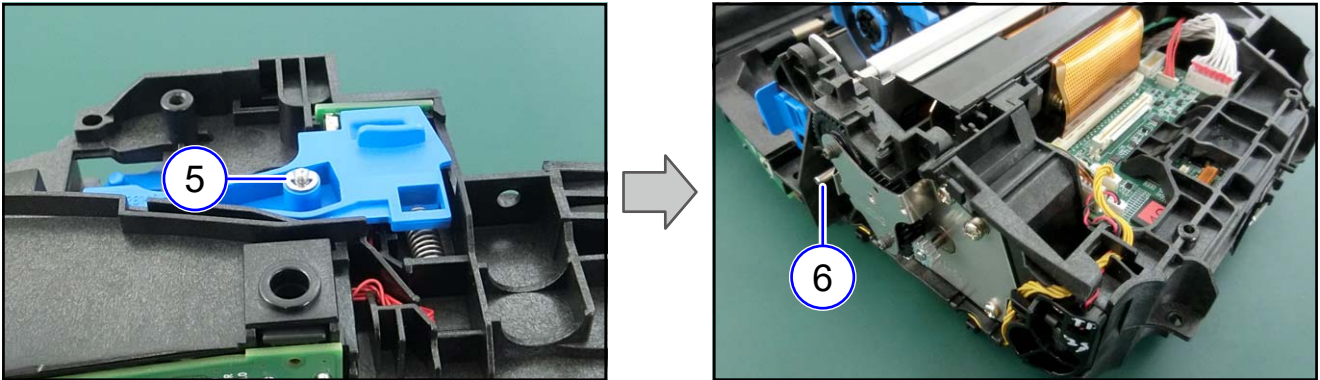

6 Remove the COVER OPEN LATCH (⑦) and LATCH SPRING (⑧).

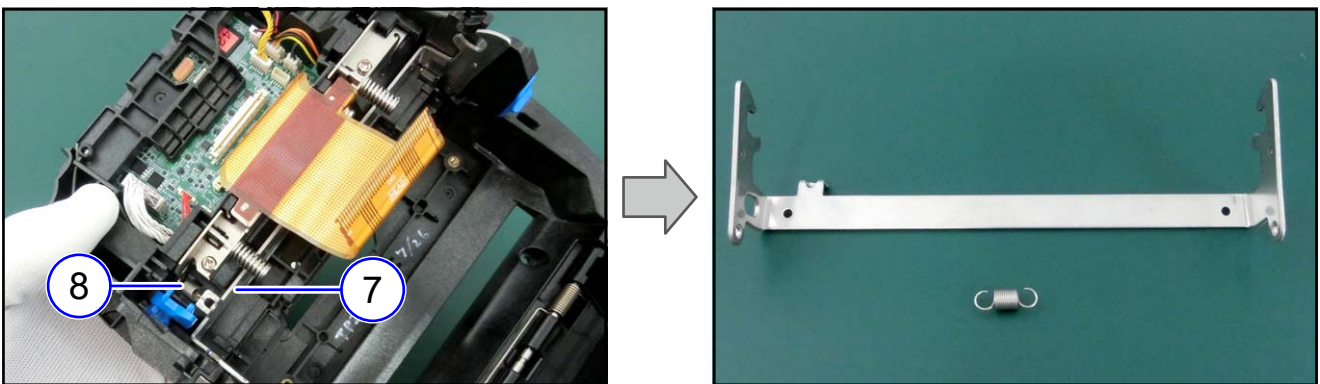

7 Release the connector lock and disconnect the FPC.

TIPS

Lift the plastic part (⑨) a little to release the connector lock.

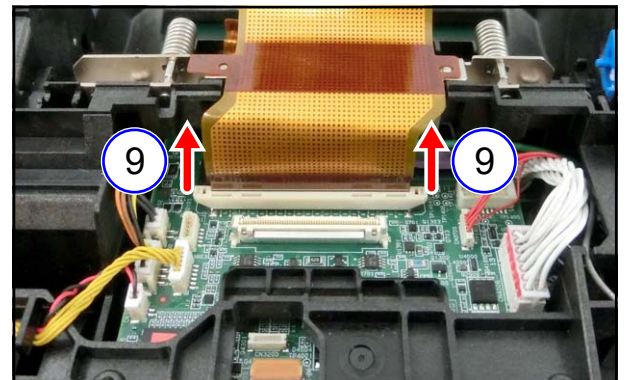

8 Remove one screw (S4).

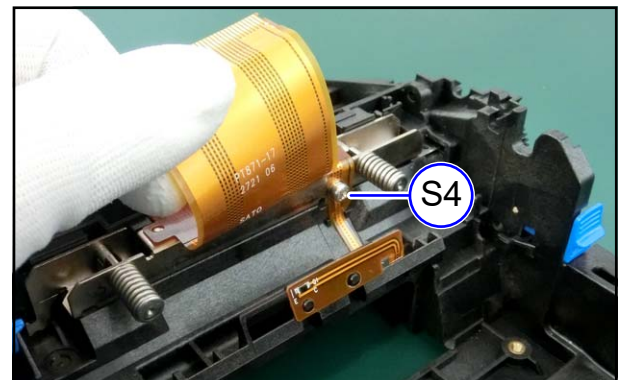

9 Remove the PW4NX-HEAD FPC ASSY-LF (⑩)

NOTE

It is fixed with double-sided adhesive tape.

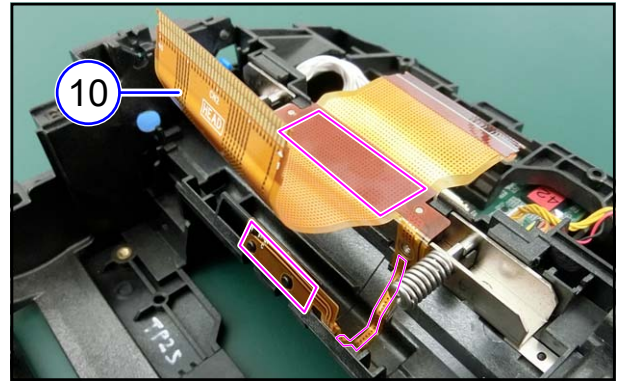

► **From here, assembling procedure**

10 Assemble the PW4NX-HEAD FPC ASSY-LF.

(1) Align it with the positioning pins and fix it with double-sided adhesive tape.

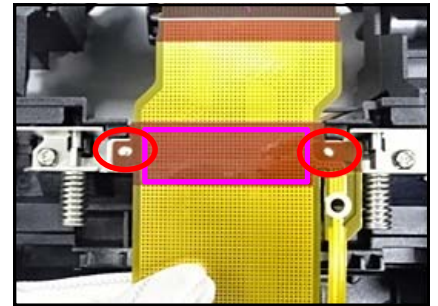

(2) Align the FPC hole with the screw hole and fix the FPC with one screw (S4).

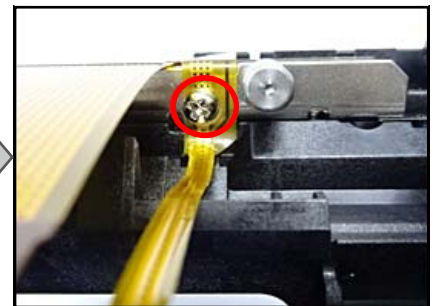
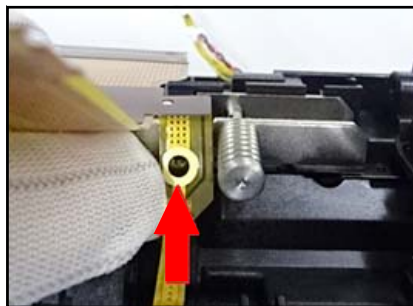

(3) Fix the FPC with double-sided adhesive tape.

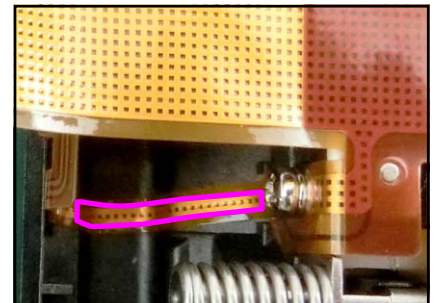

(4) Align the FPC with the positioning pins and fix it with double-sided adhesive tape.

NOTE

Fold the excess FPC.

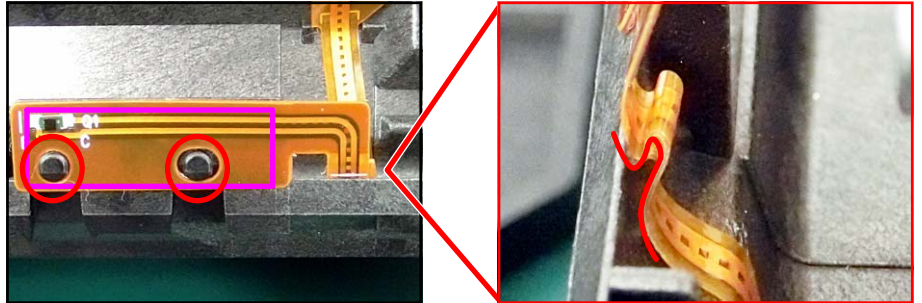

(5) Lift the plastic part a little.

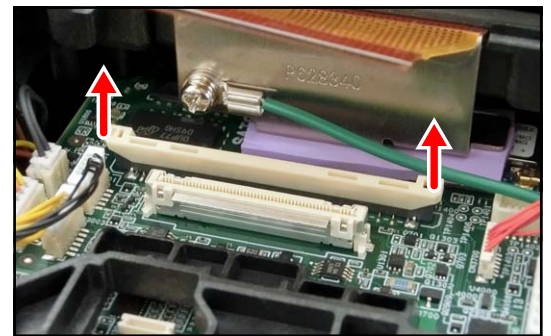

(6) Insert the FPC firmly and lower the plastic part to lock the connector.

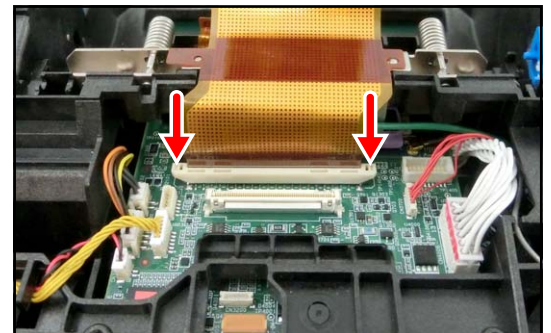

Notes on assembling

Make sure that the white line printed on the FPC is horizontal to the connector.

NG

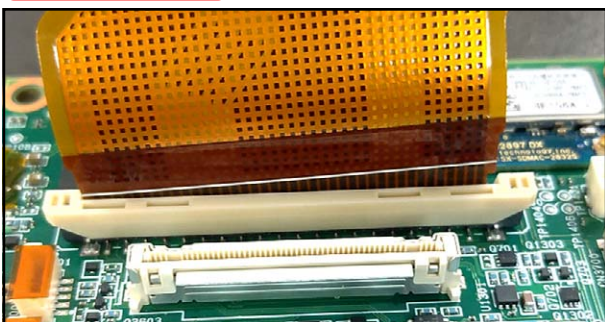

OK



11 Assemble the COVER OPEN LATCH (⑪) and LATCH SHAFT (⑫) and fix them with the E SNAP RING (⑬).

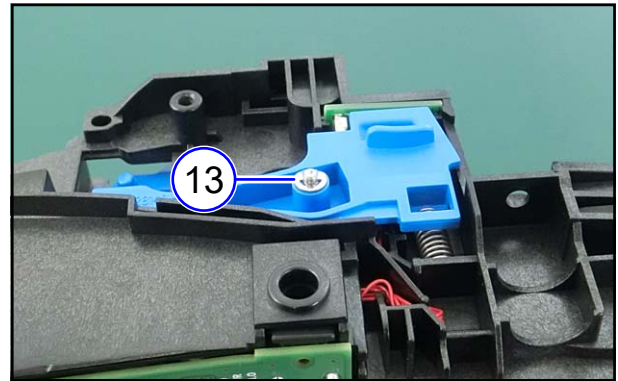
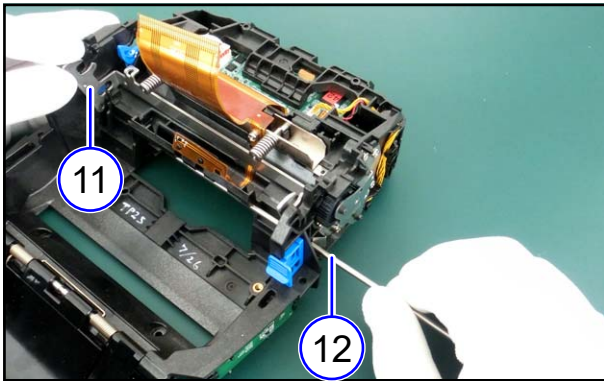

12 Attach the LATCH SPRING (⑭).

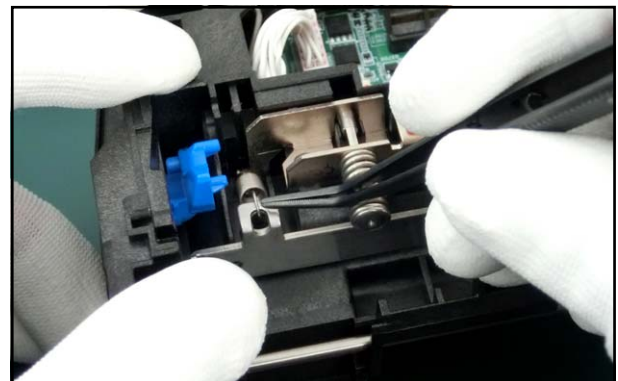
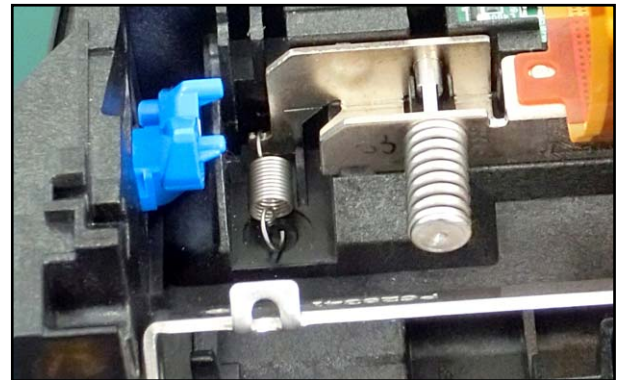
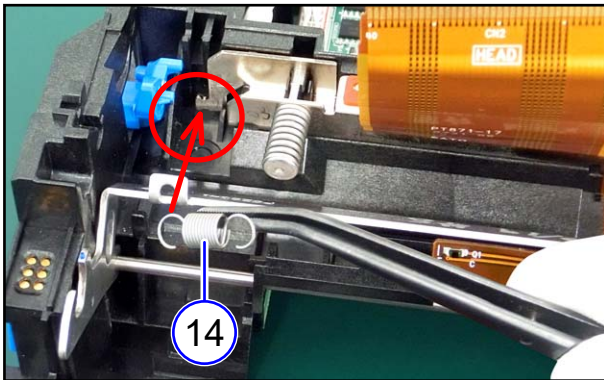

13 Reverse the procedure from step 4.

4.7 PCBs and Electrical Parts

4.7.1 Replacing the PWR PCB



10 min.



Phillips screwdriver (#2)
Phillips screwdriver (#2)



S1×6
S3×2

1 Remove the TOP COVER ASSY (①).

Refer to [4.3.1 Replacing the TOP COVER ASSY](#)

2 Remove the BOTTOM COVER ASSY (②).

Refer to [4.3.2 Replacing the BOTTOM COVER ASSY](#)

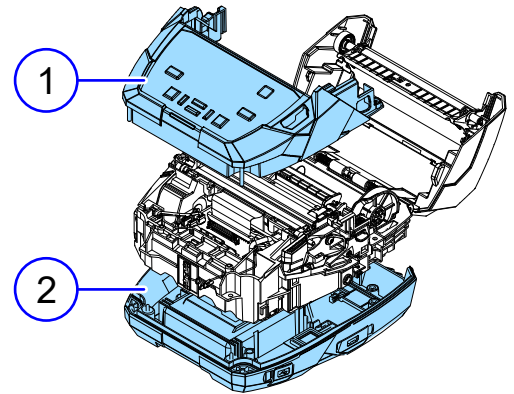

3 Disconnect one connector.

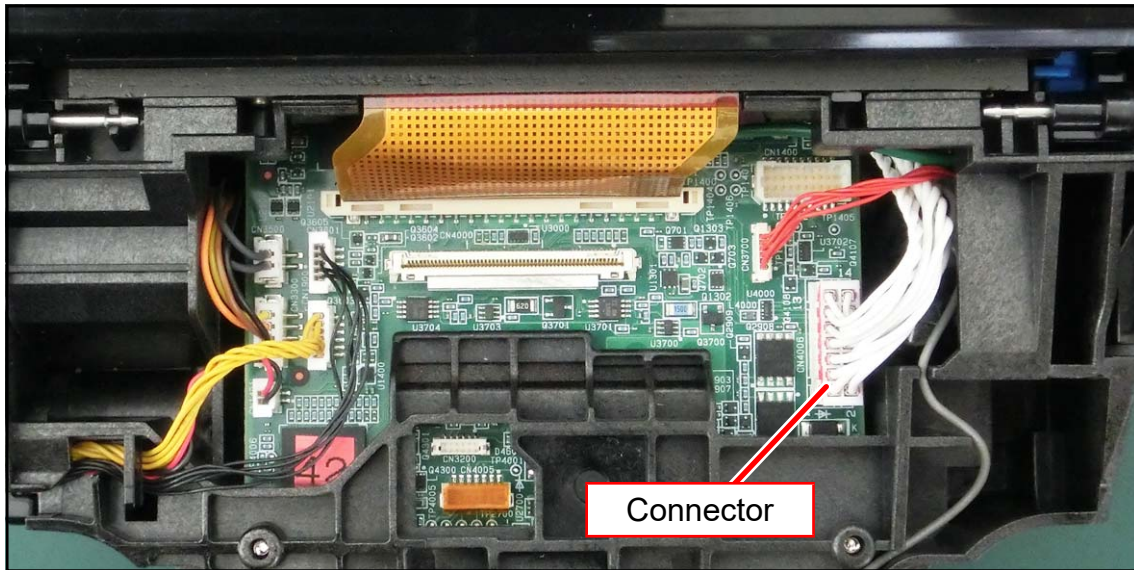

4 Remove two screws (S3).

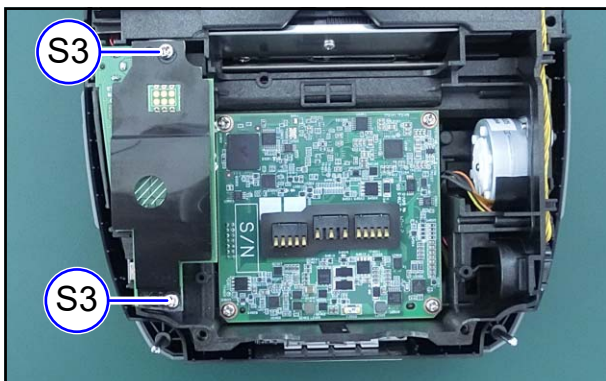

- 5** Remove the PWR PCB (③) without applying a load to the internal cables and coaxial cables.
- 6** Remove the PWR CABLE (④).

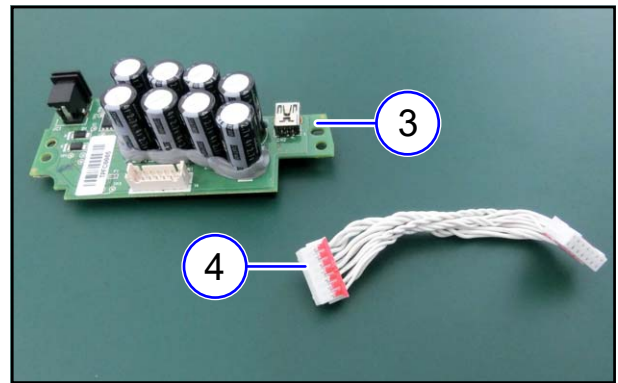
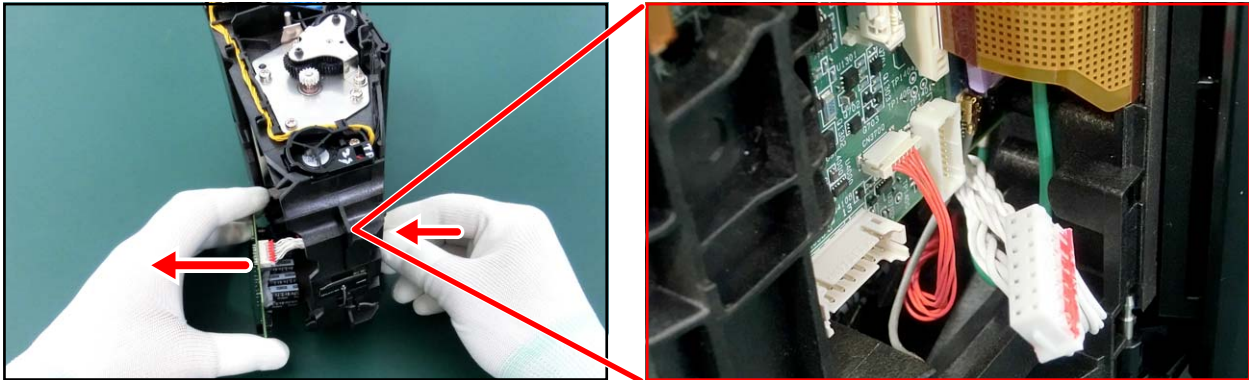

► From here, assembling procedure

- 7** Assemble the parts in the reverse order of the disassembly procedure.

4.7.2 Replacing the CONT PCB



18 min.



Phillips screwdriver (#2)
Phillips screwdriver (#2)



S1×6
S3×4

- 1 If you can access the Service menu, create clone data.
If clone data cannot be created, perform the initialization operation after getting permission from the customer.

Refer to [2.2.5 Clone](#)

- 2 Remove the TOP COVER ASSY (①).

Refer to [4.3.1 Replacing the TOP COVER ASSY](#)

- 3 Remove the BOTTOM COVER ASSY (②).

Refer to [4.3.2 Replacing the BOTTOM COVER ASSY](#)

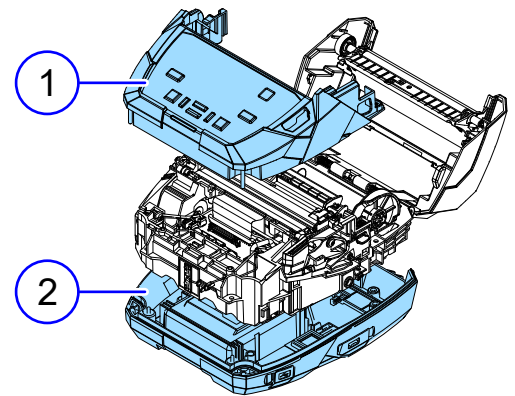

- 4 Disconnect the following connectors and FPC.

③	PWR PCB
④	IM GAP RELAY PCB
⑤	HEAD FPC (Printer head)
⑥	SPEAKER
⑦	STEPPING MOTOR
⑧	MOTOR
⑨	NFC PCB
⑩	DISP NONSEPA PCB

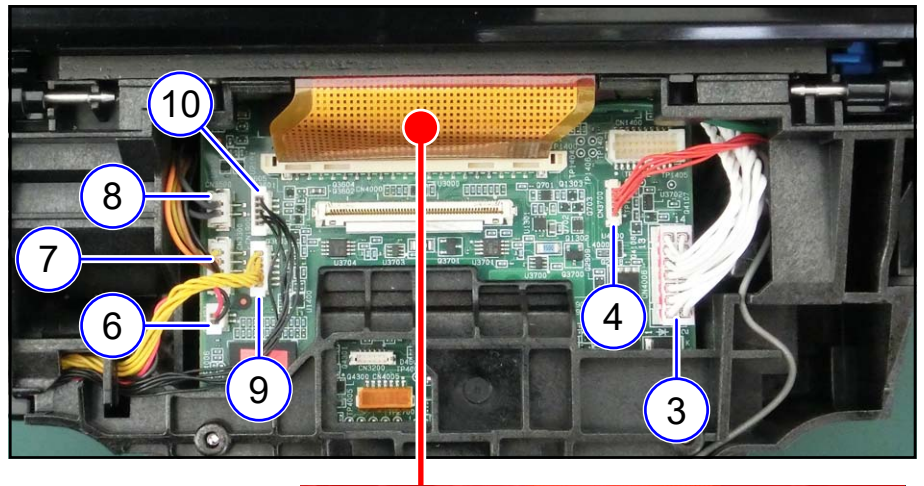

NOTE ⑤ HEAD FPC

Lift the plastic part a little to release the connector lock and disconnect the FPC.

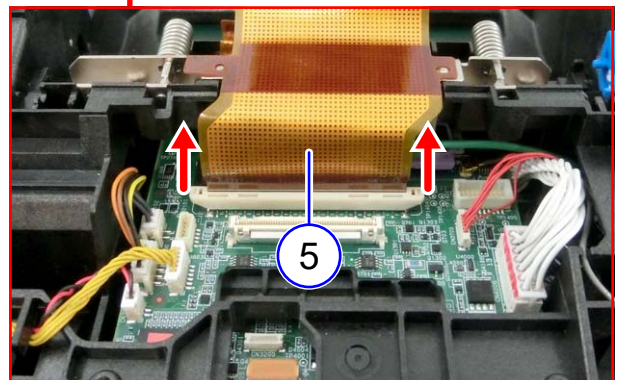

Notes on assembling ⑤ HEAD FPC

- (1) Lift the plastic part a little.
- (2) Insert the FPC firmly and lower the plastic part to lock the connector.

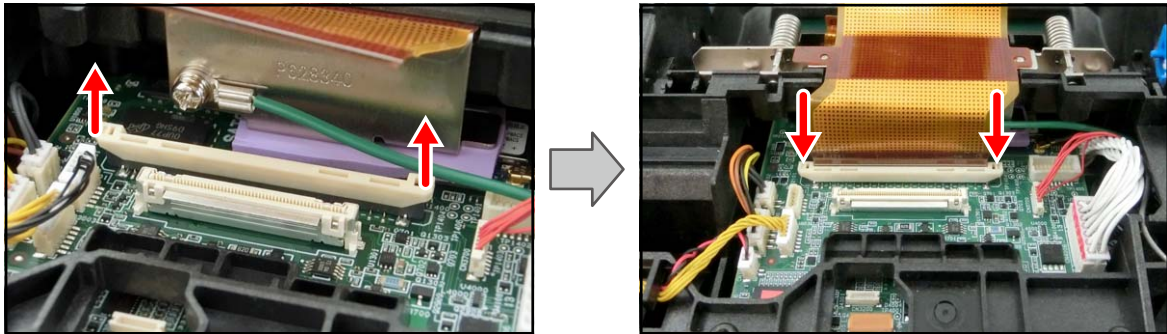

FMake sure that the white line printed on the FPC is horizontal to the connector.

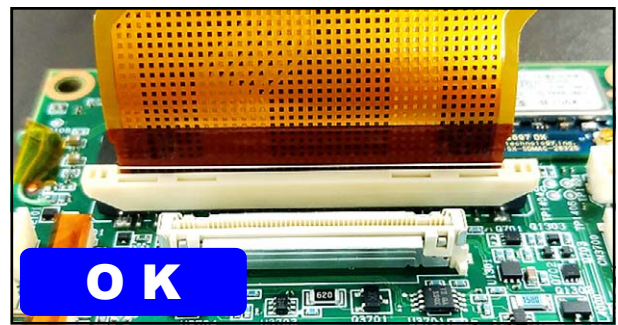
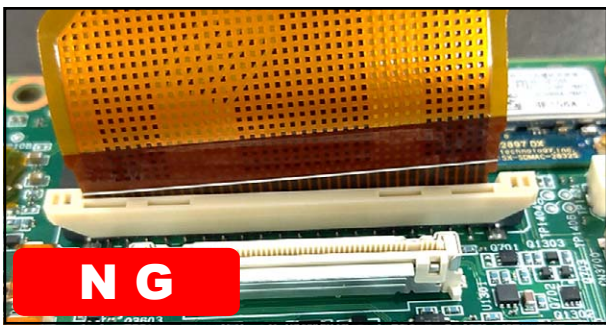

- 5 Detach the WLAN cable from the case.

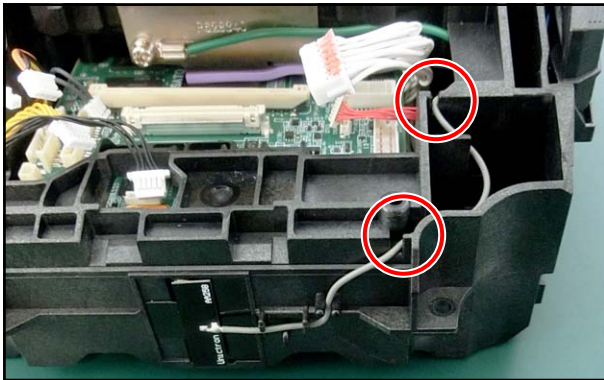

- 6 Remove four screws (S3).

S3 Fastening the ground wire together



7 Remove the CONT PCB (⑪).

NOTE

- Note that one coaxial cable remains connected to the CONT PCB.
- HEAT CONDUCTING PAD and CONT PCB are sticking together.

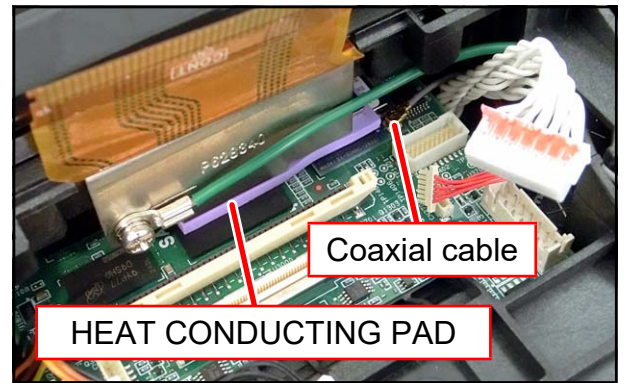

(1) Place your hand so that the CONT PCB does not fall, and lightly press the connector part to remove the CONT PCB.

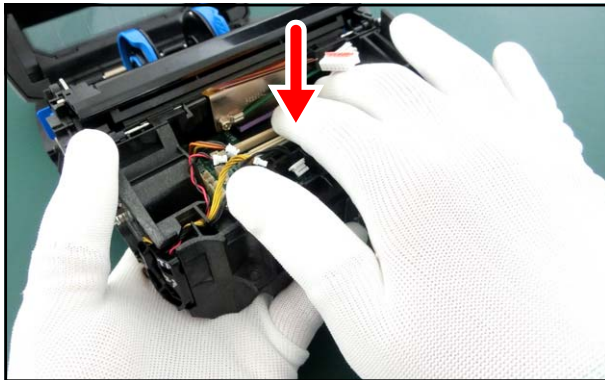

(2) Disconnect the coaxial cable.

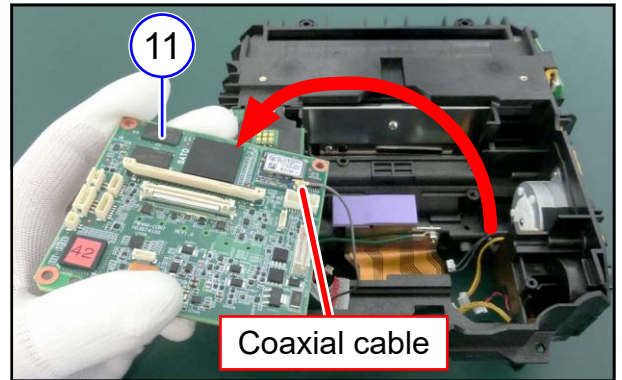

NOTE

Use the tweezers etc to vertically connect or disconnect the coaxial cable connector.

Applying force to one side of the connector only will damage the connector.

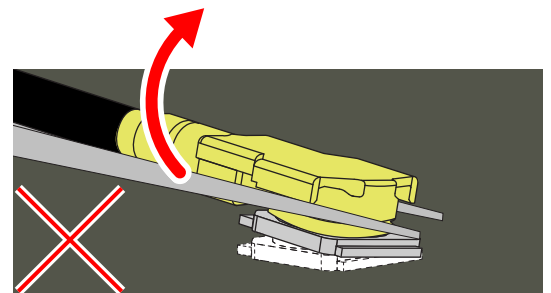

Notes on assembling

Match both connectors, and then vertically insert the cable connector into the mating connector.

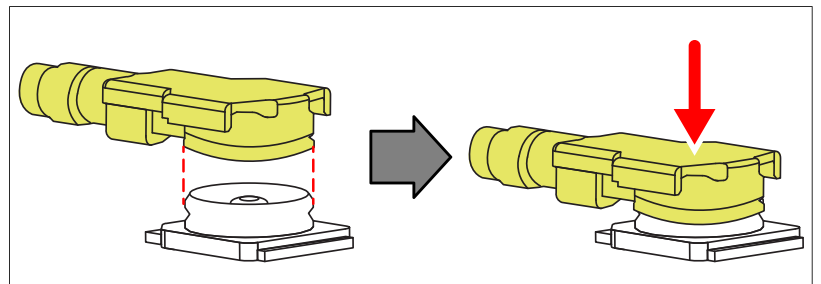

► From here, assembling procedure

8 Assemble the parts in the reverse order of the disassembly procedure.

4.7.3 Replacing the speaker

 8 min.

 Phillips screwdriver (#2)
Phillips screwdriver (#2)

 S1×6
S3×1

1 Remove the TOP COVER ASSY (①).

Refer to [4.3.1 Replacing the TOP COVER ASSY](#)

2 Remove the BOTTOM COVER ASSY (②).

Refer to [4.3.2 Replacing the BOTTOM COVER ASSY](#)

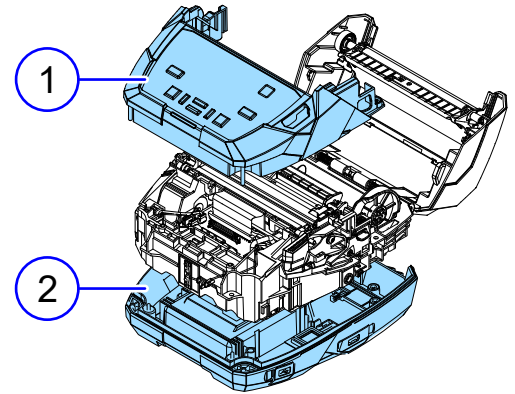

3 Disconnect one connector.

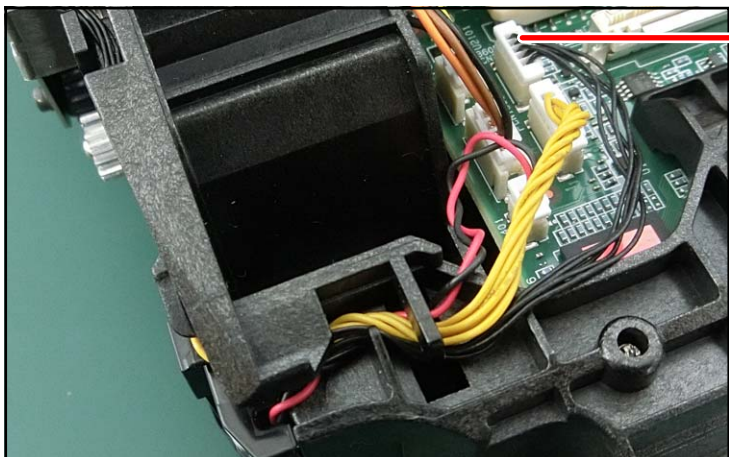

Connector

4 Remove one screw (S3) and remove the SPEAKER HOLDER (③).

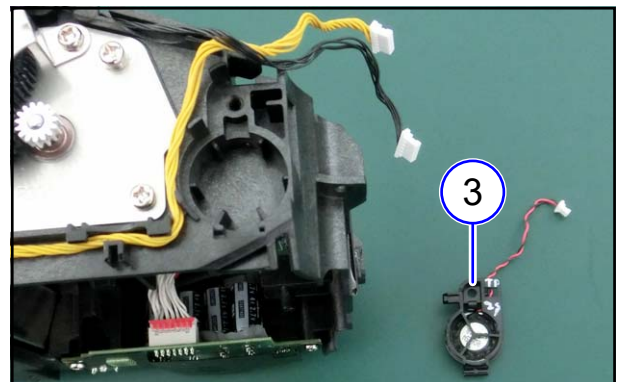
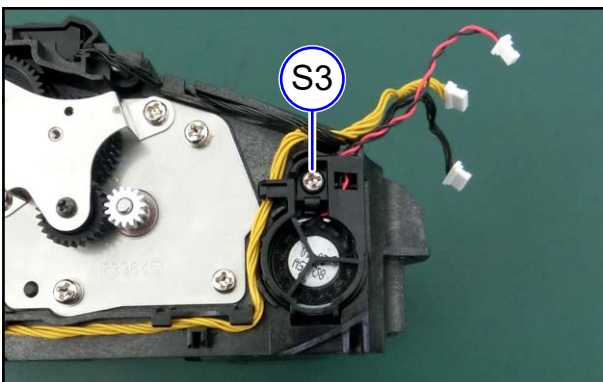

5 Release the two hooks and remove the speaker (④).

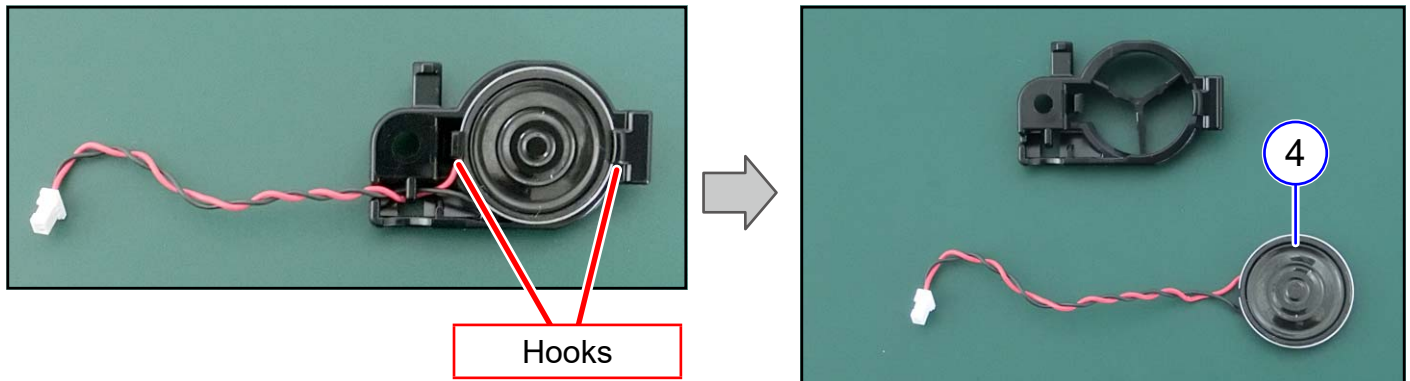

► **From here, assembling procedure**

6 Assemble the parts in the reverse order of the disassembly procedure.

4.7.4 Replacing the NFC PCB



8 min.



Phillips screwdriver (#2)



S1×6

1 Remove the TOP COVER ASSY (①).

Refer to [4.3.1 Replacing the TOP COVER ASSY](#)

2 Remove the BOTTOM COVER ASSY (②).

Refer to [4.3.2 Replacing the BOTTOM COVER ASSY](#)

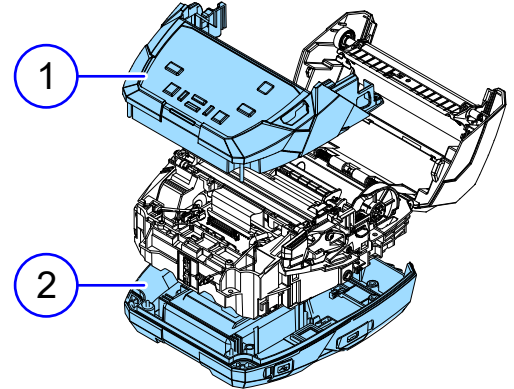

3 Disconnect the cable (③) from the case.

4 Release the hooks and remove the NFC PCB (④).

5 Disconnect the connector (⑤).

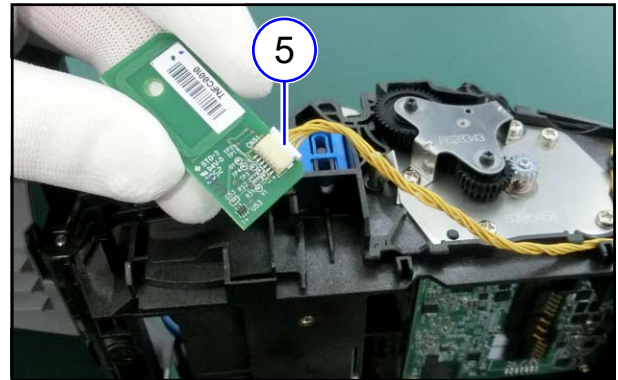
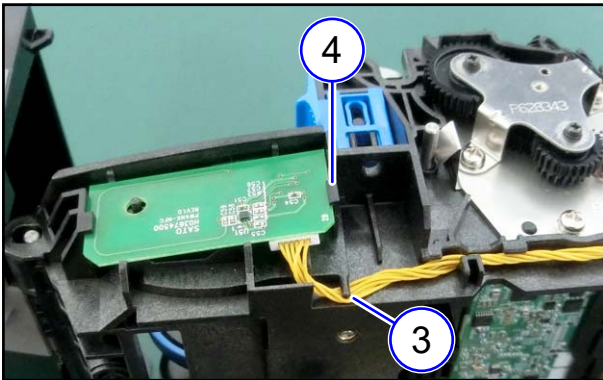

6 If you replace only the NFC PCB, no further steps are required. Assemble the removed parts in the reverse order of the disassembly procedure.

► **From here, NFC CABLE replacement procedure**

7 Detach the cable from the case.

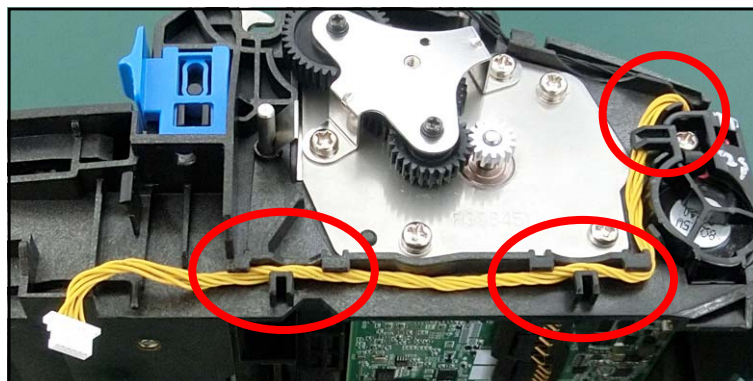

8 Disconnect connectors (1 to 3 places) according to the wiring conditions.

TIPS

In the case of the figure below, disconnect the two connectors (⑥ ⑦).

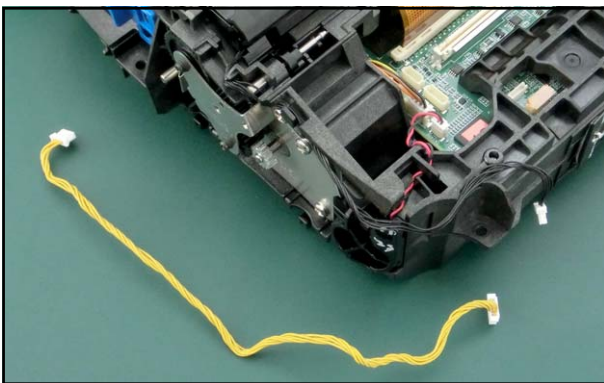
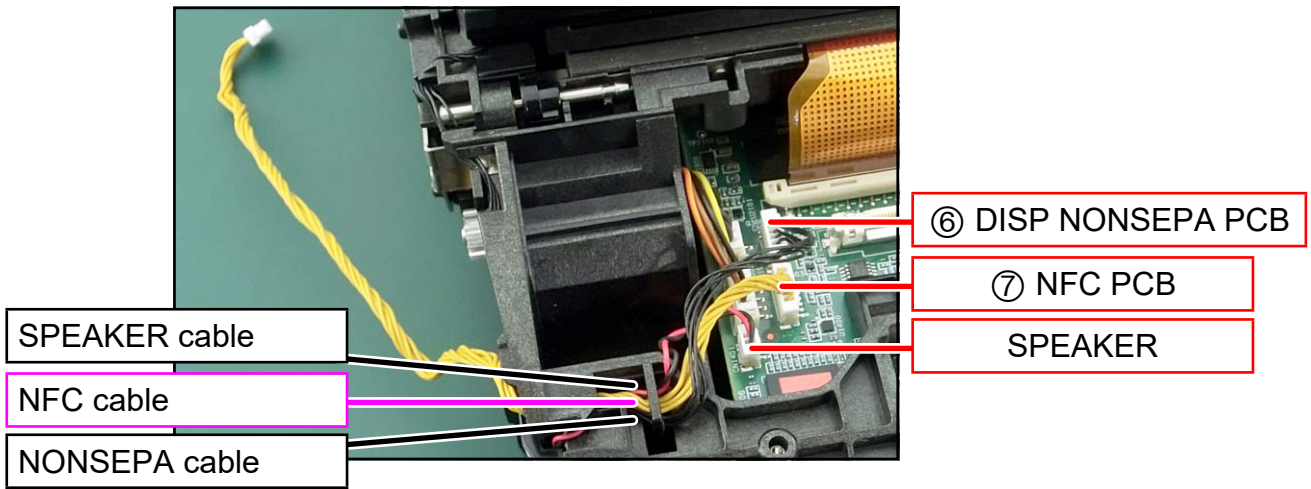

► From here, assembling procedure

9 Connect the cable to the NFC PCB and assemble the NFC PCB into the printer.

10 Attach the cable to the printer.

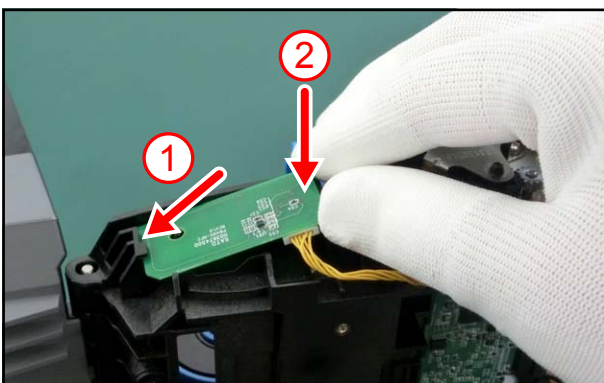

11 Reverse the procedure from step 8.

4.7.5 Replacing the WLAN ANTENA SUB



20 min.



Phillips screwdriver (#2)
Phillips screwdriver (#2)



S1×6
S3×4

1 Remove the CONT PCB (①).

Refer to [4.7.2 Replacing the CONT PCB](#)

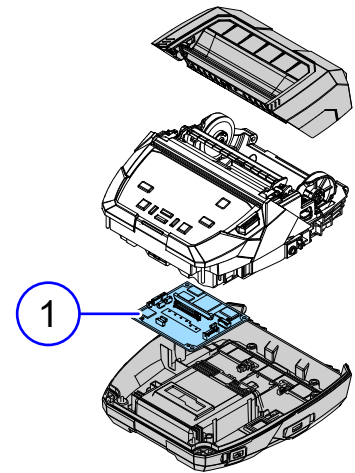

2 Remove the ANTENNA CABLE (②) that is fixed with double-sided adhesive tape.

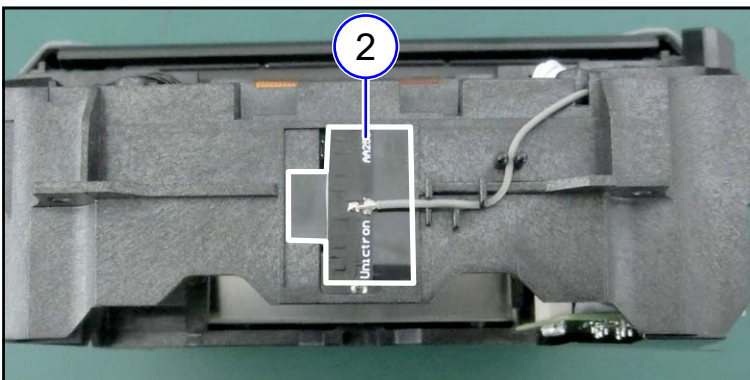

Notes on assembling

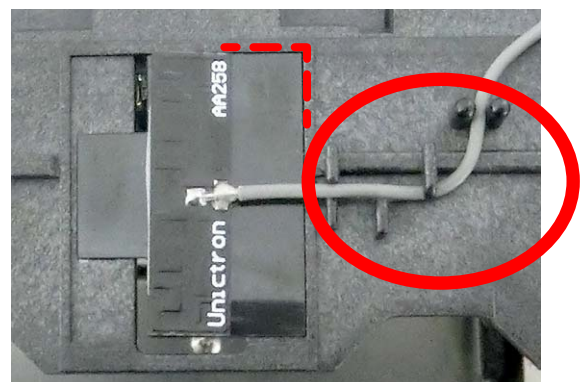
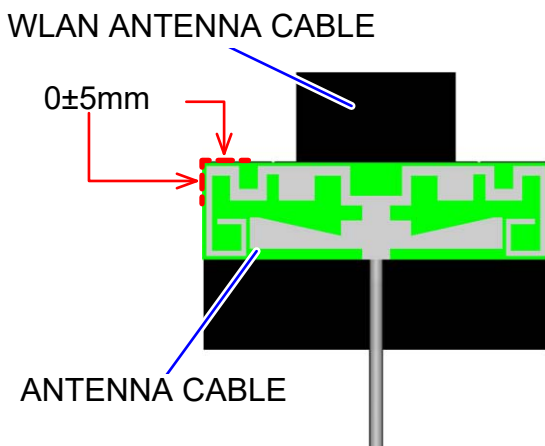

► From here, assembling procedure

3 Assemble the parts in the reverse order of the disassembly procedure.

Optional Devices	Description
Lithium-ion battery	PW4NX series only. Guideline for replacement is after about 300 charge/ discharge cycles.
AC adapter	An adapter for charging the battery installed in the product. About 3 hours for full charge.
1ch battery charger	A quick charger capable of fully charging the battery in approx. 3 hours. Equipped with the Eco Charge function. Also includes an AC adapter.
4ch battery charger	A charger capable of fully charging up to 4 batteries in approx. 4 hours. Equipped with the Eco Charge function. Also includes an AC adapter.
Charging Cradle	Cradle in which the product is placed for charging. About 3 hours for full charge. Also includes an AC adapter.
Carrying case	An option for using the product hands-free. Also includes a shoulder strap.
Hand strap	An option for easily carrying the product.
Shoulder strap	An option for using the product hands-free.
Belt loop	An option for using the product hands-free.
Cigarette lighter adapter	An adapter for charging the product from a cigarette lighter socket in a car or truck.
12-60V DC power supply	A device for charging the product by connecting directly to a DC power supply, such as the customer's battery.
Linerless kit	5. 1 Installing the Linerless kit

5.1 Installing the Linerless kit

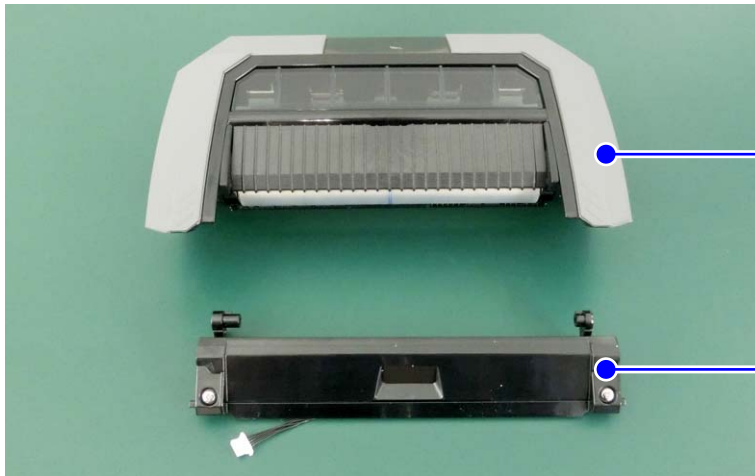

OPEN COVER ASSY (LINERLESS)

SENSOR ASSY (LINERLESS)

1 Remove the DISPENSER ASSY (①).

Refer to [4.3.4 Replacing the DISPENSER ASSY](#)

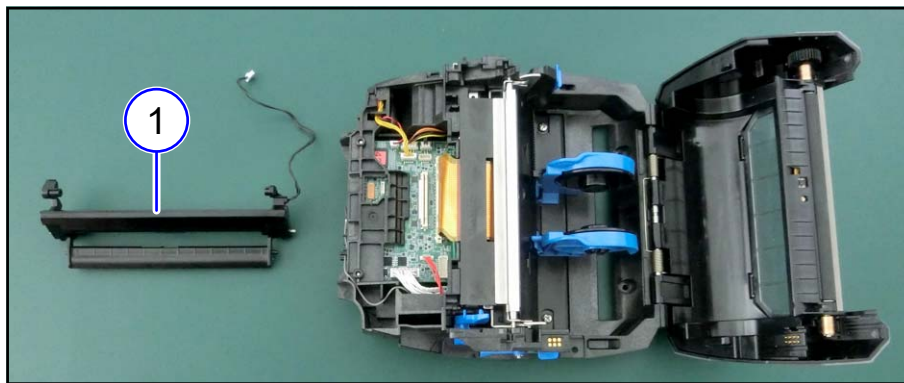

2 Install the SENSOR ASSY (LINERLESS).

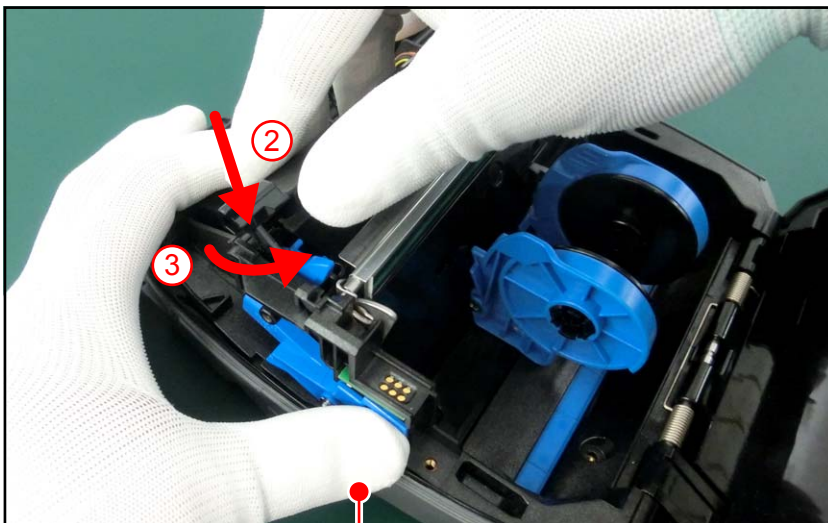

① Lower the DIS OPEN LEVER.

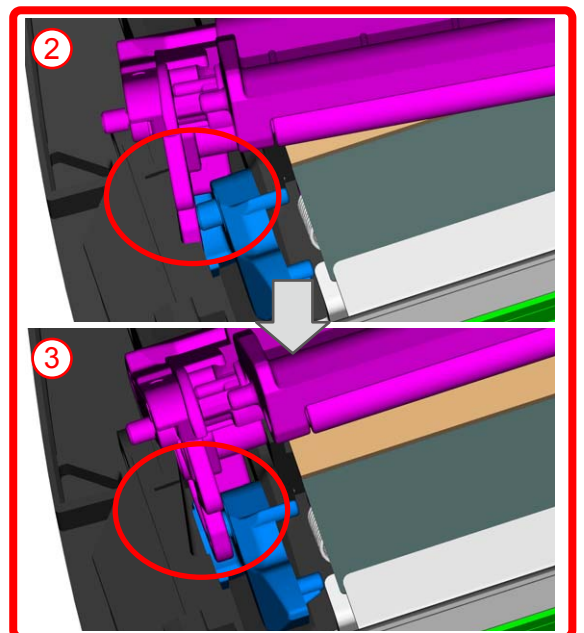

3 Insert the two DIS COVER SHAFT (②).



Notes on assembling

Securely insert the DIS COVER SHAFT.

4 Assemble the OPEN LEVER BUSH (③) and COVER OPEN LEVER (④).

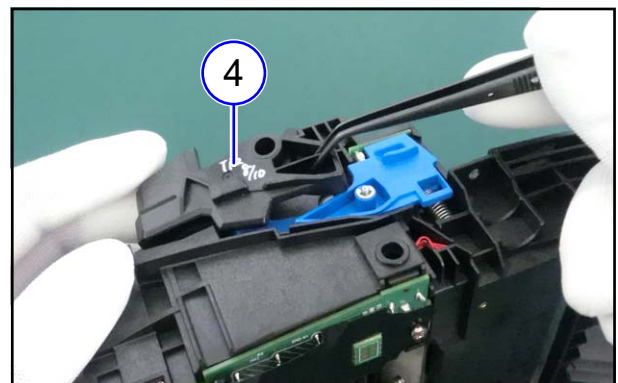
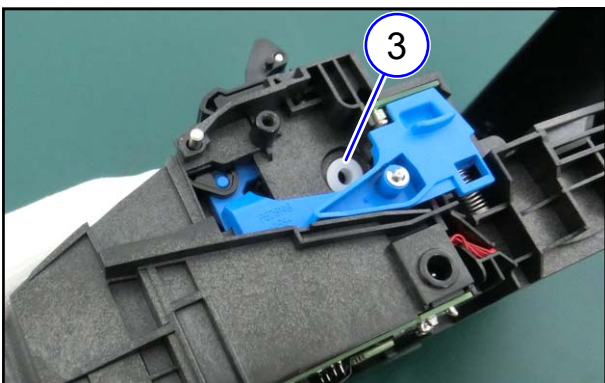

5 Tighten one screw (S5).

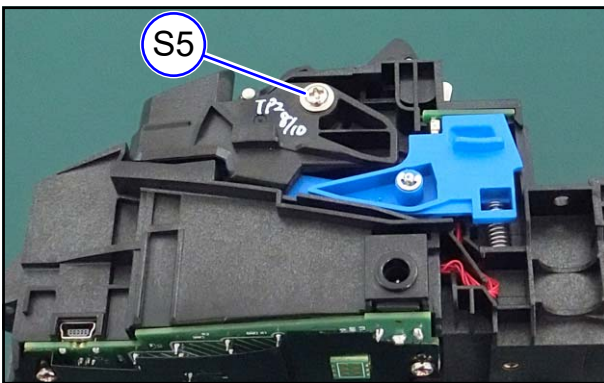

6 Put the cable in the case and connect it to the connector.

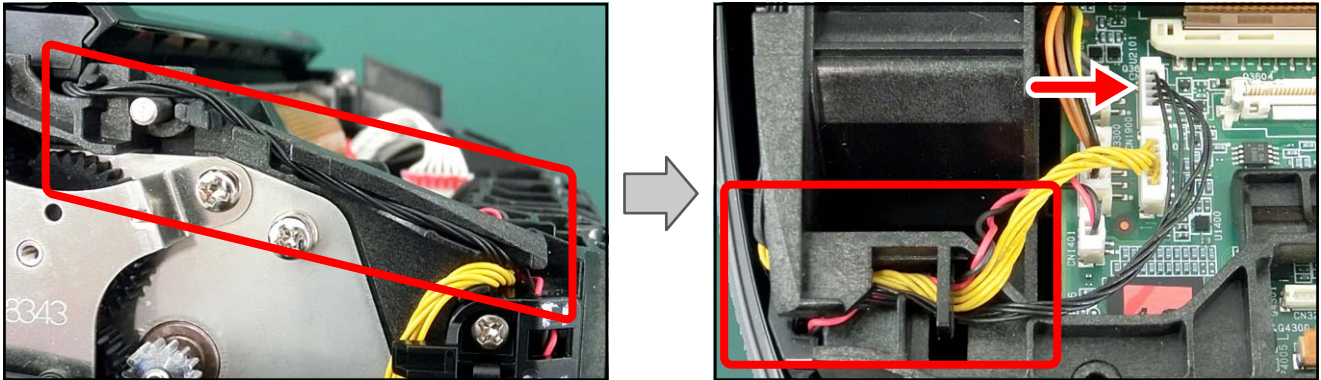

Notes on assembling

Pass the cable under the DIS COVER SHAFT (⑤).

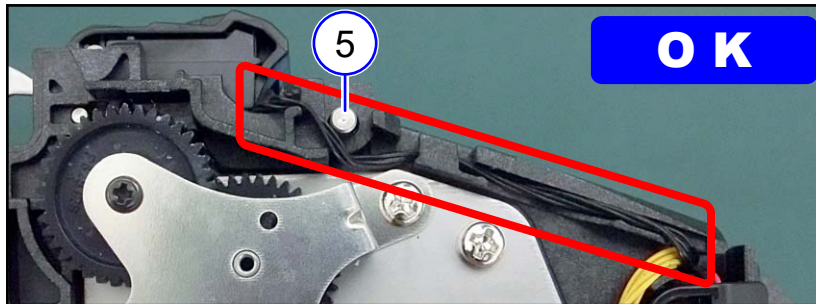

7 Pull out the HINGE SHAFT (⑥) and remove the OPEN COVER ASSY (⑦) and HINGE SPRING (⑧).

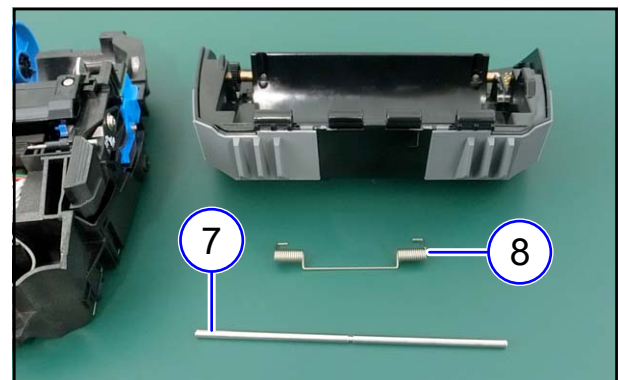
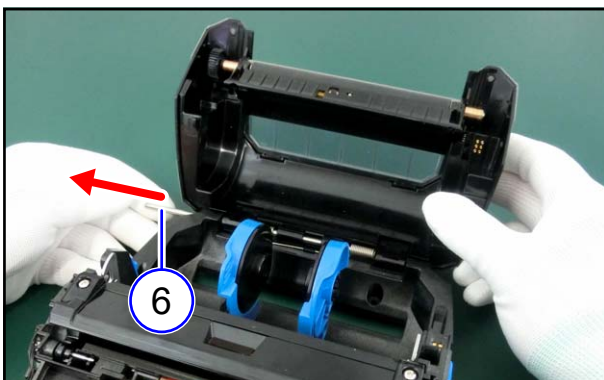

8 Put the spring into the case, paying attention to the direction.

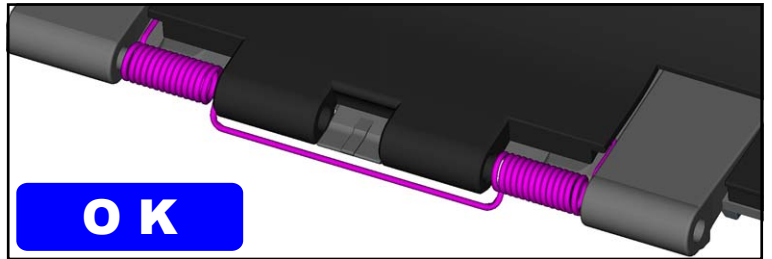
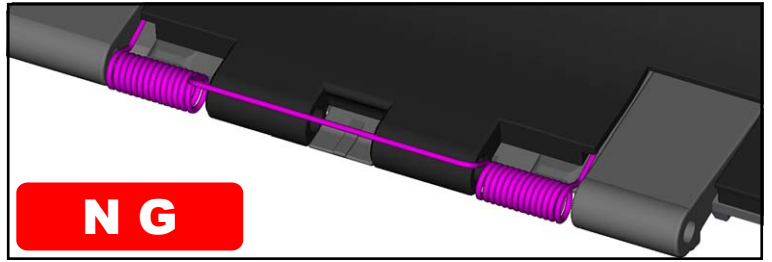
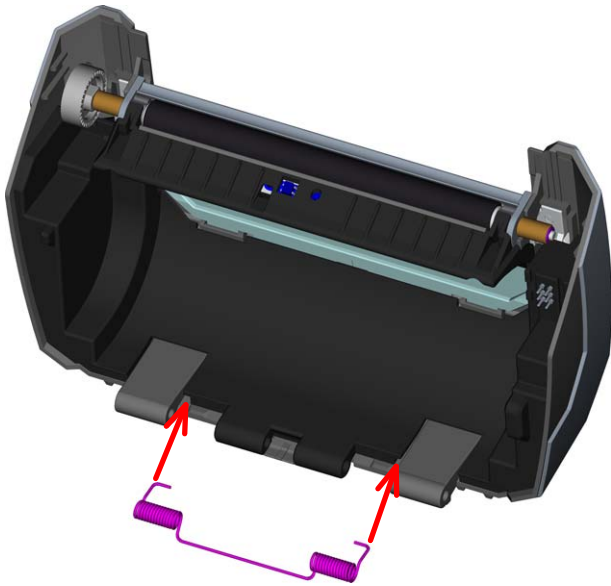

9 Hang the shaft part of the spring on the case.

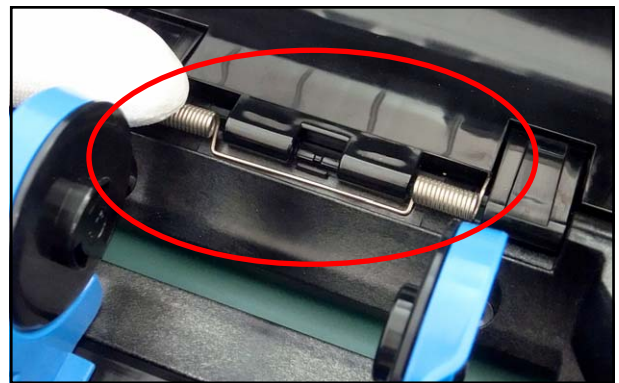
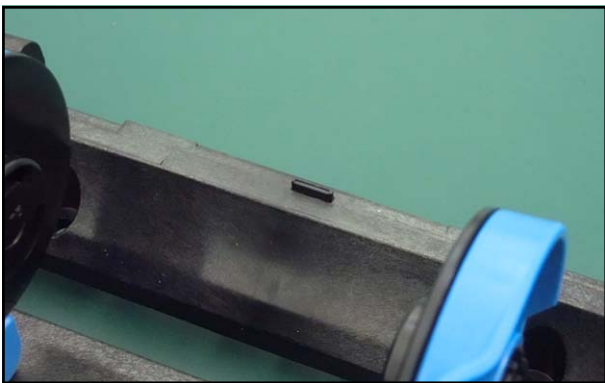

10 Attach the HINGE SHAFT (⊙).

Notes on assembling

- Insert the concave part of the HINGE SHAFT into the convex part of the case.

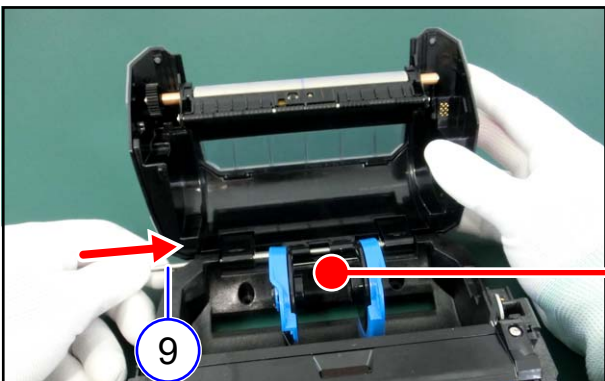

11 Attach the BOTTOM COVER ASSY.

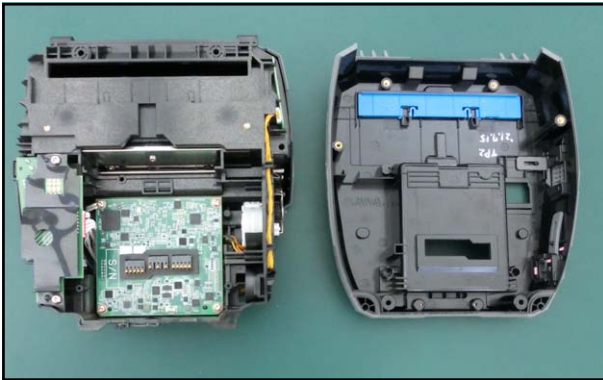

12 Connect the FPC and install the TOP COVER ASSY.

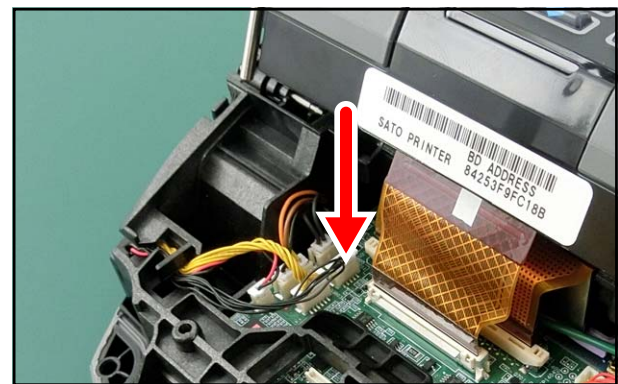

Notes on assembling

The connector lock is automatically locked when the FPC is inserted.

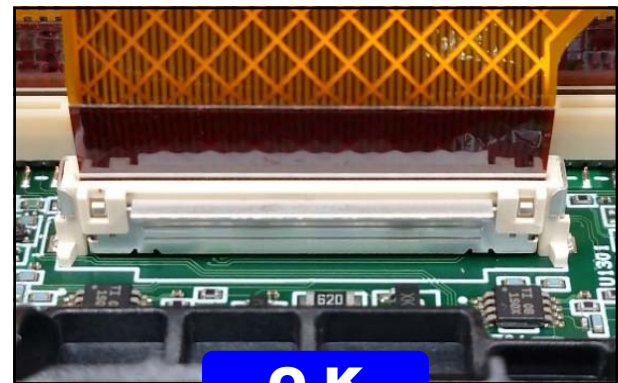

One side is not locked.

Notes on assembling

Make sure that the shafts of the TOP COVER ASSY are securely inserted into the case.



13 Tighten six screws (S1).

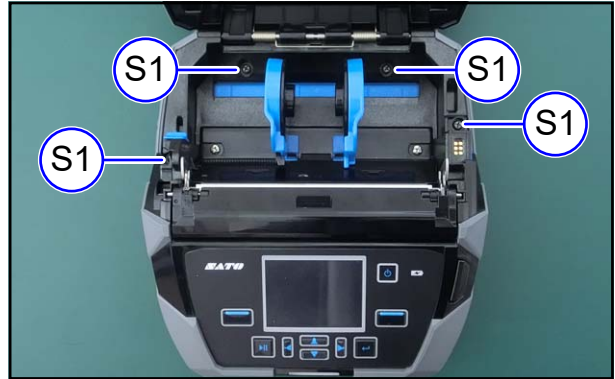
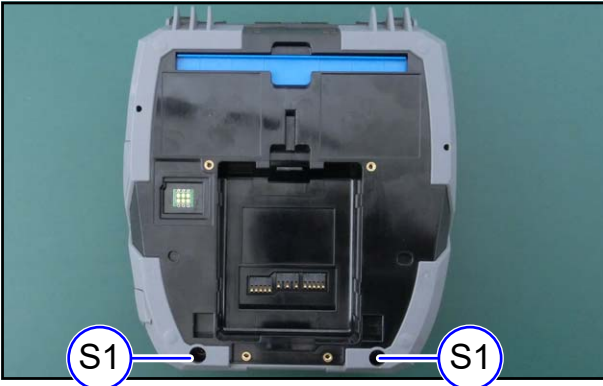

[6.1 About Error Message](#)

[6.2 Error Code List](#)

[6.3 Error List](#)

[6.4 Status Icon List](#)

6.1 About Error Message

When an error occurs, a buzzer sound, red indicator on the status LED, and an error message on the display show you the error status.

No	Menu	Description
①	Error Number	An error number is displayed.
②	Type of Error	A type of error is displayed.
③	Error Icon	A type of error is displayed in an icon.
④	Message	The procedure to clear an error is displayed.
⑤	LED Indicator	Lights in red when an error occurs.
⑥	Error Buzzer Sound	When an error occurs, a long buzzer sounds once, or a short buzzer sounds three times.

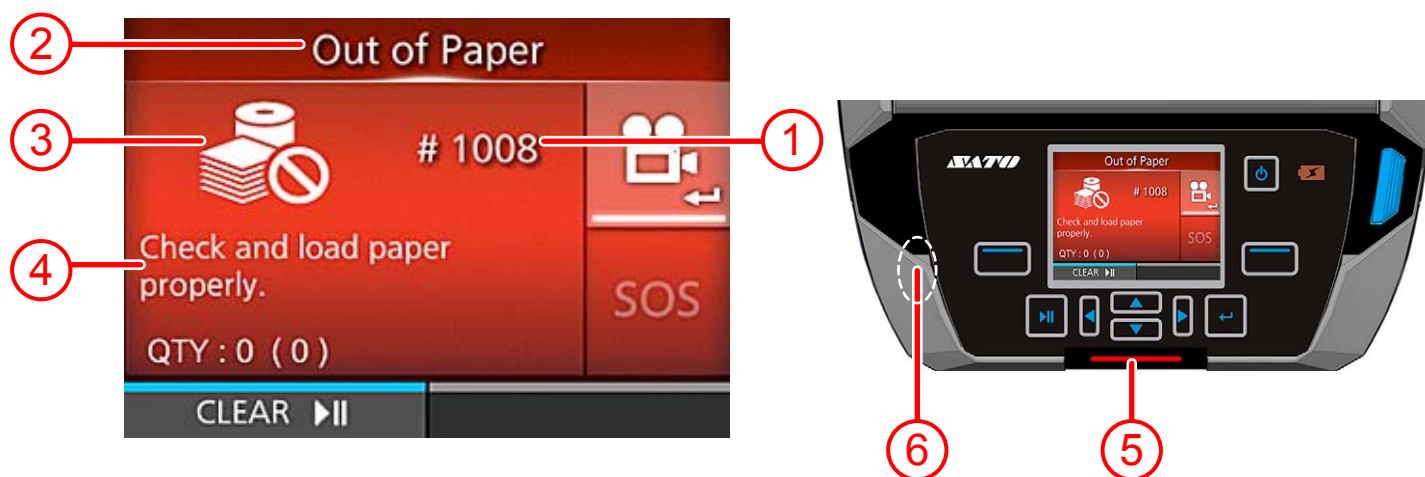

6.2 Error Code List

[Error Message 1001 \(Machine Error\)](#)

[Error Message 1007 \(Cover Open\)](#)

[Error Message 1008 \(Out of Paper\)](#)

[Error Message 1010 \(Media Error\)](#)

[Error Message 1012 \(Head Error\)](#)

[Error Message 1013 \(USB R/W Error\)](#)

[Error Message 1017 \(SBPL CMD Error\)](#)

[Error Message 1022 \(Print Head Overheated\)](#)

[Error Message 1023 \(NTP Error\)](#)

[Error Message 1028 \(GAP Not Found\)](#)

[Error Message 1035 \(I-mark Not Found\)](#)

[Error Message 1043 \(Low Battery\)](#)

[Error Message 1046 \(EAP Authentication Error \(EAP Failure\)\)](#)

[Error Message 1047 \(EAP Authentication Error \(EAP Timeout\)\)](#)

[Error Message 1050 \(Bluetooth Error\)](#)

[Error Message 1058 \(CRC Check Error\)](#)

[Error Message 1059 \(Battery Low\)](#)

[Error Message 1060 \(No Battery\)](#)

[Error Message 1061 \(Battery Degradation\)](#)

[Error Message 1062 \(Battery Temperature Error\)](#)

[Error Message 1063 \(Battery Error\)](#)

[Error Message 1064 \(Motor Overheated\)](#)

[Error Message 1066 \(Paper Jam\)](#)

[Error Message 1067 \(Charging\)](#)

[Error Message 1068 \(WLAN Error\)](#)

[Error Message 1070 \(Battery wearing out\)](#)

[Error Message 1071 \(Worn out battery\)](#)

[Error Message 1072 \(Power Off Error\)](#)

[Error Message 1075 \(NFC Error\)](#)

[Error Message 1076 \(Invalid command in NFC\)](#)

[Error Message 1099 \(Config Warning\)](#)

[Error Message 1128 \(Bluetooth MFi Chip Module Error\)](#)

[Error Message 1137 \(Invalid Dispenser Setup\)](#)

[Error Message 1138 \(Battery Lock\)](#)

[Error Message 1139 \(Battery Low \(Print\)\)](#)

6.3 Error List

Error Number	Type of Error	Error Icon	LED	Buzzer
1001	Machine Error		Light in red	Long sound, one time
Message	Recycle power. Contact technical support if not resolved.			
To clear the display	Power off the product.			
Causes / Countermeasures				
Check the detail numbers on the right side of the error title.		Machine Error [018]		
Number	Description	Countermeasure		
001	Sensor CPU activation and continuity check at start up	Replace board		
002	Receive sensor CPU data at start up			
003	Transmit sensor CPU data			
004	Receive sensor CPU data (failed to read data)			
005	Receive sensor CPU data (no data)			
006	MSCC main thread abnormality ended (others)			
007	Create interface buffer			
008	Head check	Replace board, check/replace print head		
009	Initialize MSCC	Replace board		
010	SCC initialization setting			
011	—	—		
012	Notification to MSCC to start sleep + UI version of LED control	Replace board		
013	—	—		
014	LED control to MSCC	Replace board		
015	Received invalid format data			
016	CRC error failure notification			
017	SUB rising due to static electricity			
018	Initialization failed at start up			
101	Print speed setting			
102	Strobe adjustment			
103	Motor initialization	Replace board		
104	Initialization of overheat detection (communication error at SCPU)			
105	AC power control initialization			
106	Initialize FPGA	Image update, replace board		

Error Number	Type of Error	Error Icon	LED	Buzzer
1007	Cover Open		Light in red	Short sound, 3 times
Message	Close cover. Attention : Print head is high temperature.			
To clear the display	Close the top cover.			
Causes	1) The top cover is open. 2) The sensor for detecting the open/close status of the top cover is defective.			
Countermeasures	1) Close the top cover so that it clicks when locked. 2) Contact your technical support.			

1008	Out of Paper		Light in red	Short sound, 3 times
Message	Check and load paper properly.			
To clear the display	Open the top cover and load media or press the left select button (CLEAR) or LINE button.			
Causes	1) The media is not loaded. 2) The media is not loaded correctly. 3) The media sensor level is not set correctly. 4) The media sensor is dirty, or there is a label attached to it. The media sensor has poor sensitivity.			
Countermeasures	1) 2) Load the media correctly. 3) Adjust the media sensor level. 4) Clean the media sensor. * Refer to the operator manual for details.			

Error Number	Type of Error	Error Icon	LED	Buzzer
1010	Media Error		Light in red	Short sound, 3 times
Message	Print is too long or wrong settings. Adjust print data or sensor settings.			
To clear the display	Open and close the top cover or press the left select button (CLEAR) or LINE button.			
Causes	<ol style="list-style-type: none"> 1) The media size of the print data and the actual media size are different. 2) The media size of the print data is longer than the actual media size. 3) The media is fed a longer distance due to the incorrect sensor level. 			
Countermeasures	<ol style="list-style-type: none"> 1) Check the media size of the print data and the actual media size again. If the error is not solved, power on the product again. 2) Check the print data. If the error is not solved, power on the product again. 3) Adjust the media sensor level. If the error is not solved, power on the product again. 			

1012	Head Error		Light in red	Long sound, one time
Message	Replace print head or change head check settings.			
To clear the display	Press and hold the left select button (CLEAR) for 5 seconds to switch to Offline mode and temporarily disable the head check until the product is powered off.			
Causes	<ol style="list-style-type: none"> 1) The print head is defective. 2) The print head is worn or damaged. 			
Countermeasures	<ol style="list-style-type: none"> 1) 2) Replace the print head.			

1013	USB R/W Error		Light in red	Long sound, one time
Message	Unknown partition type. Remove USB memory.			
To clear the display	Connect the USB memory and then disconnect it, or press the left select button (CLEAR) or LINE button.			
Causes	<ol style="list-style-type: none"> 1) The USB memory is disconnected while writing. 2) The copy area in the USB memory is not sufficient. 3) Writing to the USB memory fails. 4) The USB memory is not formatted. 			
Countermeasures	<ol style="list-style-type: none"> 1) Connect the USB memory. 2) Make sure that the USB memory has sufficient copy area. 3) Replace the USB memory. 4) Format the USB memory to FAT32 format. 			

Error Number	Type of Error	Error Icon	LED	Buzzer
1017	SBPL CMD Error		Light in red	Short sound, 3 times
Message	C003:<X>:Invalid command			
To clear the display	Press the left select button (CLEAR) or LINE button.			
Causes	<p>Incorrect command or parameter is detected in the print data.</p> <p>Check the display of “Caaa: <bb>: cc” for error details.</p> <p>Caaa: Location of Error Occurrence <bb>: Error command name cc: Error descriptions (codes)</p> <p>The error contents are as follows:</p>			
	Invalid command	Analyzed improper command.		
	Invalid parameter	Received improper parameter.		
	Command table read error	Failed to read the command table.		
	Invalid graphic data/ custom designed data	Analyzed improper graphic and custom designed data.		
	Invalid registration area	<ul style="list-style-type: none"> Specified memory area (card slot) is inappropriate. Tried to write to a write-protected media. 		
	This number is already registered.	Number specified by registration command has already been taken.		
	Over registration area limit	Exceeded the registration area. (Memory full)		
	Data is not registered	Data, such as form overlay, is not registered.		
	Printing position is out of printable area	The specified print start position is outside the printable area.		
	Barcode image is out of printable area	The printing image is outside the printable area. (Barcode only)		
	PDF417 is specified incorrectly	There is a mistake in the PDF417 specification.		
	Error in generating QR code	There was a fault when generating the QR code.		
Countermeasures	<p>Check the print data.</p> <p>If the problem persists, restart the printer.</p>			

Error Number	Type of Error	Error Icon	LED	Buzzer
1022	Print Head Overheated		Light in red	Long sound, one time
Message	Printer is overheated. Please wait to cool off.			
To clear the display	Stop the operation of the product to let the temperature decrease.			
Causes	The temperature of the product has exceeded its tolerance value.			
Countermeasures	Stop the operation of the product to let the temperature decrease.			

1023	NTP Error		Light in red	Long sound, one time
Message	No contact with time server. Check IP address and LAN settings.			
To clear the display	Press the left select button (CLEAR) or change the network settings.			
Causes	<ol style="list-style-type: none"> 1) Could not connect to the time server and set the date and time. 2) There was a mistake in the network settings or a network malfunction occurred. 			
Countermeasures	<ol style="list-style-type: none"> 1) Confirm that the address of the time server is correct. Confirm that there is a connection to the time server. 2) Check the network settings and the network environment. 			

1028	GAP Not Found		Light in red	Short sound, 3 times
Message	Adjust sensor settings to match label type or clean sensor.			
To clear the display	Open and close the top cover or press the left select button (CLEAR) or LINE button.			
Causes	<ol style="list-style-type: none"> 1) Meandering media. 2) A label is attached to the media sensor. 3) The media sensor type is incorrect. 4) The media sensor level is incorrect. 			
Countermeasures	<ol style="list-style-type: none"> 1) Load the media correctly. 2) Clean the media sensor. 3) Set the media sensor type which is compatible with the media you use. 4) Adjust the media sensor level. 			

Error Number	Type of Error	Error Icon	LED	Buzzer
1035	I-mark Not Found		Light in red	Short sound, 3 times
Message	Adjust sensor settings to match label type or clean sensor.			
To clear the display	Open and close the top cover or press the left select button (CLEAR) or LINE button.			
Causes	<ol style="list-style-type: none"> 1) Meandering media. 2) A label is attached to the media sensor. 3) The media sensor type is incorrect. 4) The media sensor level is incorrect. 			
Countermeasures	<ol style="list-style-type: none"> 1) Load the media correctly. 2) Clean the media sensor. 3) Set the media sensor type which is compatible with the media you use. 4) Adjust the media sensor level. 			

1043	Low Battery		Light in red	Short sound, 3 times
Message	Please charge battery.			
To clear the display	Connect an AC adapter and charge the battery so that the low battery level is cleared. The product is automatically powered off after 30 to 40 seconds.			
Causes	The battery is running low.			
Countermeasures	Charge or replace the battery.			

1046	EAP Authentication Error (EAP Failure)		Light in red	Short sound, 3 times
Message	Erroneous Wi-Fi settings. Adjust settings.			
To clear the display	Change the Wi-Fi settings or press the left select button (CLEAR).			
Causes	EAP Authentication failure.			
Countermeasures	Use the correct Wi-Fi settings.			

Error Number	Type of Error	Error Icon	LED	Buzzer
1047	EAP Authentication Error (EAP Timeout)		Light in red	Short sound, 3 times
Message	Authentication timed out. Check AP and server configurations.			
To clear the display	Press the left select button (CLEAR).			
Causes	The Access Point (AP) setting and authentication server setting do not match.			
Countermeasures	Check the Access Point (AP) setting and authentication server setting.			

1050	Bluetooth Error		Light in red	Long sound, one time
Message	Disable Bluetooth or repair Bluetooth module.			
To clear the display	Press the left select button (CLEAR).			
Causes	The Bluetooth module is not recognized.			
Countermeasures	Replace the CONT PCB.			

1058	CRC Check Error		Light in red	Short sound, 3 times
Message	Signature does not match. Verify the transmitted data.			
To clear the display	Press the left select button (CLEAR) or the right select button (PRINT).			
Causes	1) CRC has not been added to the data. 2) CRC does not match.			
Countermeasures	1) 2) Check transmitted data and interface settings. [PRINT]: Continue printing from the print data where the CRC error occurred. [CANCEL]: Cancel the print data where the CRC error occurred and continue printing from the next item.			

Error Number	Type of Error	Error Icon	LED	Buzzer
1059	Battery Low		Light in red	Short sound, 3 times
Message	Please wait for battery to charge.			
To clear the display	Charge the product until printing is possible.			
Causes	The battery is being charged with low battery status.			
Countermeasures	Charge the product so that it can perform printing.			

1060	No Battery		Light in red	Short sound, 3 times
Message	Please insert battery.			
To clear the display	Insert the battery.			
Causes	1) The battery is disconnected. 2) The battery is not inserted.			
Countermeasures	1) 2) Insert the battery.			

1061	Battery Degradation		Light in red	Long sound, one time
Message	Please change battery.			
To clear the display	Replace the battery.			
Causes	The battery has deteriorated.			
Countermeasures	Replace the battery.			

1062	Battery Temperature Error		Light in red	Short sound, 3 times
Message	Please use battery within the use temperature.			
To clear the display	Replace the battery.			
Causes	The battery temperature is abnormal.			
Countermeasures	Replace the battery.			

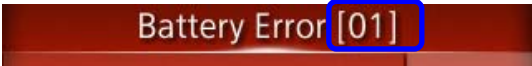
Error Number	Type of Error	Error Icon	LED	Buzzer
1063	Battery Error		Light in red	Long sound, one time
Message	Please change battery.			
To clear the display	Replace the battery.			
Causes / Countermeasures				
Check the detail numbers on the right side of the error title.				
Number	Description	Countermeasure		
001	Battery communication abnormal (i2c error)	Replace battery,replace board		
002	Continuous normal charging timeout abnormal	Replace battery, replace board, replace AC adapter		
003	Continuous backup charging timeout abnormal			
004	Over charging abnormal	—		
005	—			
006	Blown fuse error	Replace battery		

Error Number	Type of Error	Error Icon	LED	Buzzer
1064	Motor Overheated		Light in red	Long sound, one time
Message	Please wait for motor to cool down.			
To clear the display	Stop the operation of the product to let the temperature decrease.			
Causes	The temperature of the product has exceeded its tolerance value.			
Countermeasures	Stop the operation of the product to let the temperature decrease.			

Error Number	Type of Error	Error Icon	LED	Buzzer
1066	Paper Jam		Light in red	Short sound, 3 times
Message	Open print cover and load label again.			
To clear the display	Open the top cover and load the media again.			
Causes	<ol style="list-style-type: none"> 1) The media has jammed. 2) The media is not loaded correctly. 3) Something, such as glue, is stuck to the media path, and a feed problem has occurred. 4) A label is attached to the media sensor. 			
Countermeasures	<ol style="list-style-type: none"> 1) Remove the jammed media. 2) Load the media correctly. 3) Clean the inside of the product. 4) Clean the media sensor. 			

Error Number	Type of Error	Error Icon	LED	Buzzer
1067	Charging		Light in red	Short sound, 3 times
Message	Please wait for charging to complete.			
To clear the display	Wait until charging of the battery is complete. Or, stop charging the battery.			
Causes	You cannot power off the product during charging.			
Countermeasures	Power off the product after charging is complete.			

1068	WLAN Error		Light in red	Long sound, one time
Message	Contact technical support.			
To clear the display	Press the left select button (CLEAR).			
Causes	The wireless LAN module is damaged.			
Countermeasures	Replace the WLAN unit.			

1070	Battery wearing out		Light in red	Short sound, 3 times
Message	[Notice]Please replace battery.			
To clear the display	Press the left select button (CLEAR).			
Causes	The battery is exhausted. It is recommended that the battery should be replaced. The operation time may become short and printing quality may become poor.			
Countermeasures	Replace the battery.			

1071	Worn out battery		Light in red	Short sound, 3 times
Message	[Warning!]Please replace battery.			
To clear the display	Press the left select button (CLEAR).			
Causes	The battery is exhausted. Replace the battery. The operation time may become short and printing quality may become poor.			
Countermeasures	Replace the battery.			

Error Number	Type of Error	Error Icon	LED	Buzzer
1072	Power Off Error		Light in red	Short sound, 3 times
Message	Was not properly powered off. Please check your settings.			
To clear the display	Press the left select button (CLEAR).			
Causes	The product has not been correctly powered off. (The battery is disconnected.)			
Countermeasures	<ul style="list-style-type: none"> • Power off the product, and then remove the battery. • Check the setting information. 			

1075	NFC Error		Light in red	Long sound, one time
Message	Contact technical support.			
To clear the display	Press the left select button (CLEAR).			
Causes	The NFC module is not operating correctly.			
Countermeasures	Replace the NFC module.			

1076	Invalid command in NFC		Light in red	Short sound, 3 times
Message	Failed to install settings from NFC.			
To clear the display	Press the left select button (CLEAR).			
Causes	A command error occurs and the settings are not saved correctly.			
Countermeasures	Check the command. If the problem persists, replace the CONT PCB.			

1099	Config Warning		Light in red	Short sound, 3 times
Message	Configuration Initialization			
To clear the display	Press the left select button (CLEAR).			
Causes	The product has not been correctly powered off. (The battery is disconnected or other problem exists.)			
Countermeasures	Power off the product correctly. Reset the product in the Settings menu.			

Error Number	Type of Error	Error Icon	LED	Buzzer
1128	Bluetooth MFi Chip Module Error		Light in red	Long sound, one time
Message	Contact technical support.			
To clear the display	Press the left select button (CLEAR).			
Causes	The MFi chip in the Bluetooth module is damaged.			
Countermeasures	Replace the CONT PCB.			

1137	Invalid Dispenser Setup		Light in red	Short sound, 3 times
Message	Please confirm the dispenser unit and the Print Mode setting.			
To clear the display	Open and close the top cover or press the left select button (CLEAR) or LINE button.			
Causes	The dispenser unit status is different from the print mode settings, when printing.			
Countermeasures	If the dispenser unit is pulled out, then set [Print Mode] to [Dispenser]. If the dispenser unit is not set up, then set something other than [Dispenser].			

1138	Battery Lock		Light in red	Short sound, 3 times
Message	Power Off after 30 seconds if it cannot be unlocked			
To clear the display	Do the following "Countermeasure" to release the battery lock condition.			
Causes	The battery's battery lock protection has activated because the product was used continuously in a high temperature or low-temperature environment, or high print-ratio printing was done continuously.			
Countermeasures	Remove the battery from the product, and then wait about 10 seconds. Charge the battery with the AC adapter (option) or the battery charger (option) If it is not resolved, replace the battery.			

1139	Battery Low (Print)		Light in red	Short sound, 3 times
Message	not enough motor drive voltage.			
To clear the display	Open and close the top cover or press the left select button (CLEAR) or LINE button.			
Causes	Low battery detected while printing.			
Countermeasures	Charge or replace the battery.			





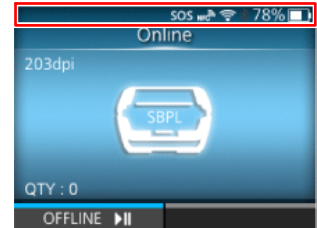



6.4 Status Icon List

The status icons are displayed in the status bar indicated by the red frame.



Communication Interface Status

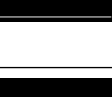





Icon	Description
	Bluetooth is enabled but not connected.
	Bluetooth is enabled and connected.
	Bluetooth startup failed.
	NFC is enabled but not connected.
	NFC is enabled and connected.
	Not connected to the NTP time server.
	Wi-Fi is authenticated, but not connected.
	Wi-Fi startup failed
	Wi-Fi is connected. Signal Level: 1
	Wi-Fi is connected. Signal Level: 2
	Wi-Fi is connected. Signal Level: 3
	Wi-Fi is connected. Signal Level: 4

Icon	Description
	Wi-Fi Direct is connected or the product is set to act as an access point.
	Product is connected to USB host.
	Standard code is disabled.
	The On-Demand mode of the SOS (SATO Online Services) is enabled.
	The Real Time mode or the Light mode of the SOS is enabled. The product is connected to the SOS cloud.
	The Real Time mode or the Light mode of the SOS is enabled, but not connected to the SOS cloud. If the Wi-Fi icon is grayed out, the product is not connected to the network. If the Wi-Fi icon is active, the Internet connection of the SOS cloud has a trouble.
	The product is not connected to the SOS cloud.
	Time period set for periodic notification for On-Demand mode for SOS has been reached. Scan the QR code and send the information to the SOS cloud.
	IP address could not be acquired. Or a communication error has occurred.

USB Memory Status



Icon	Description
	USB memory is connected.

Print Job Status





Icon	Description
	Waiting for media removal. Remove the media.
	Command error detected. Check the print data.
	Receive buffer is nearly full. Stop sending print data until the buffer is no longer nearly full.
	Defective print head is detected. Replace the print head.
	Incompatible print head is detected. Replace the print head.
	Dispenser sensor failed due to strong exterior light. To output the next media, remove the media, and go to online mode.

Maintenance Status



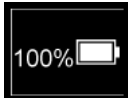

Icons notify you about cleaning the product and replacing parts at the set periods when [Notifications] is enabled.

Icon	Description
	Clean the print head or platen roller.
	Replace the print head.
	Replace the platen roller.

Battery Status (When [Eco Charge] is Disabled)

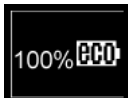
Icon	Description
	Shows the remaining battery level in an icon and percent.
	Shows that the battery is charging.
	Shows that the battery is not in a chargeable temperature range and cannot be charged.
	Shows that it is time to replace the battery.
	

Battery Status (When [Eco Charge] is Enabled)

Icon	Description
	Shows the remaining battery level in percent.
	Shows that the battery is eco-charging.
	Shows that the battery is not in a chargeable temperature range and cannot be charged.
	Shows that it is time to replace the battery.
	

Reference

This chapter describes the following:

[1 Location of Sensors and Options](#)

[2 Guidelines for replacing parts \(Confidential\)](#)

1 Location of Sensors and Options

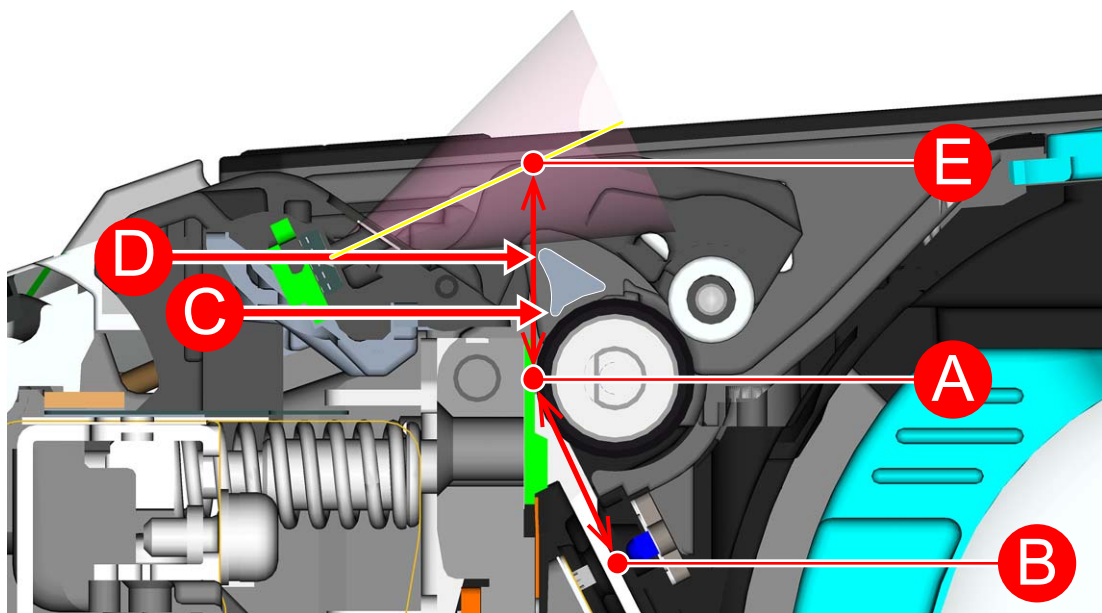
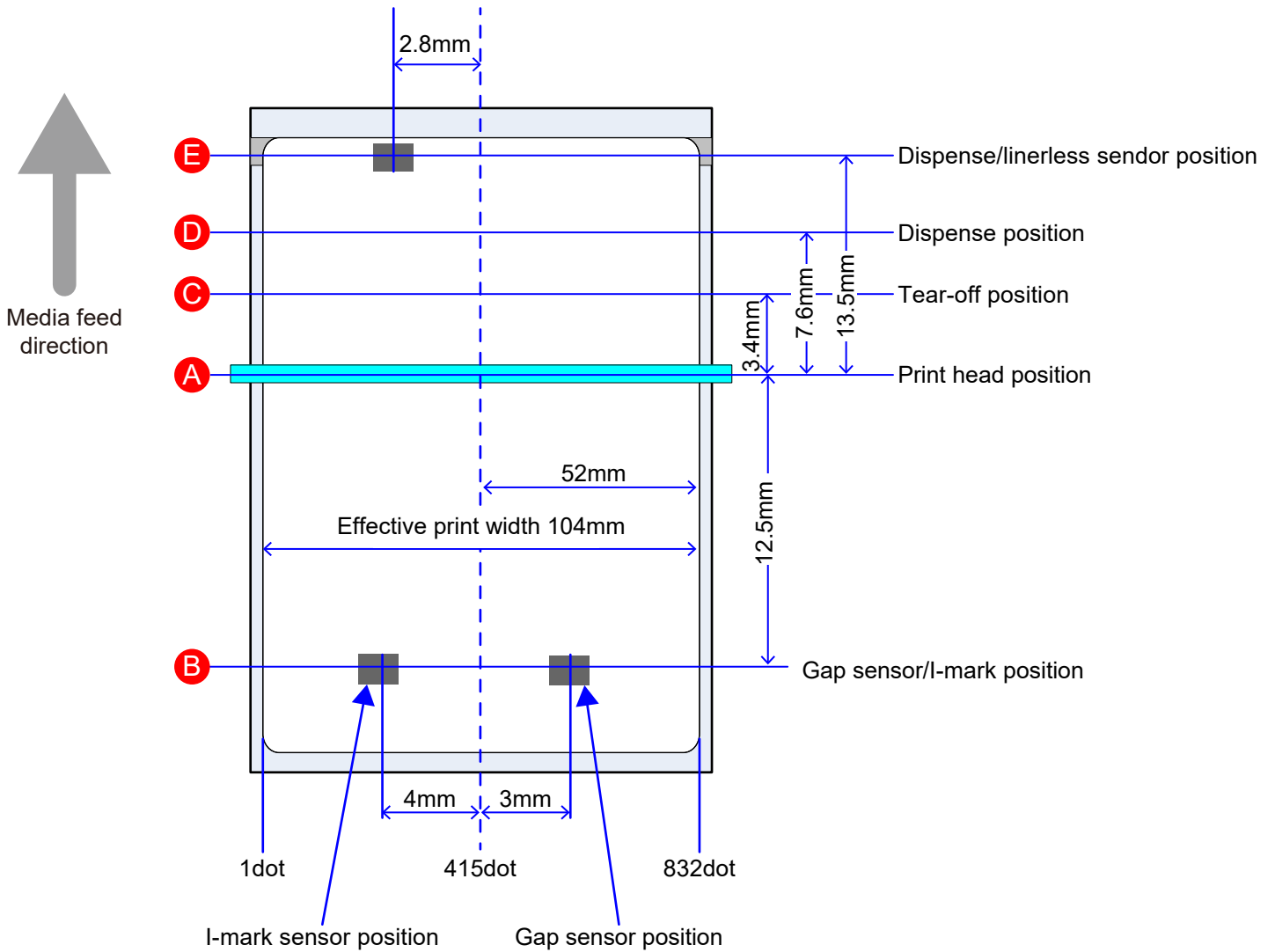

2 Guidelines for replacing parts (Confidential)

Durability		
Print head (Thermal head)	30 km	
Platen roller	30 km	
Platen roller (Linerless)	15 km	
Motor (motor drive time)	3,000 hours or more	
CONT PCB	22,500 hours or more	
Sensors Conditions: Within the current and temperature specifications	20,000 hours or more	
LCD	20,000 hours or more	
AC adapter	15,000 hours or more	
Battery	600 times/SOH 60%	
Product life	50 km or 5 years	
Precision of print position		
Print start position (Media feed direction)	±1.3 mm	
Width direction position	±1.0 mm	
Expansion and contraction accuracy in printing		
Continuous, Tear-off, Cutter, Dispenser	±1%	
Linerless	+1% / -4%	
Print mode		
Continuous	Sensor enabled, Sensor disabled	
Tear-off	Sensor enabled, Sensor disabled	
Dispenser	Sensor enabled	Motion 1 (Backfeed after printing) Motion 2 (Backfeed before printing) No backfeed
Linerless	Sensor enabled/disabled	Motion 2 (Backfeed before printing)

Media

Media types		Media roll (face-out), Fan-fold
Media forms		According to “Supply product specifications”
Media thickness (upper part media + liner)		58 to 190.5 μm (0.058 to 0.1905 mm)
Continuous	Length	13 to 305 mm (16 to 308 mm, including the liner)
	Width	38 to 111 mm (including the liner / Media roll 38 to 111 mm) (including the liner / Fan-fold 38 to 111 mm)
Tear-off	Length	16 to 305 mm (19 to 308 mm, including the liner)
	Width	38 to 111 mm (including the liner / Media roll 38 to 111 mm) (including the liner / Fan-fold 38 to 111 mm)
Dispenser	Length	16 to 254 mm (19 to 257 mm, including the liner)
	Width	38 to 111 mm (including the liner / Media roll 38 to 111 mm) (including the liner / Fan-fold 38 to 111 mm)
Linerless	Length	16 to 257 mm
	Width	38 to 114 mm
Media roll	Roll diameter	Maximum $\phi 67$ mm ($\phi 2.6$ inches)
	Core inner diameter	$\phi 19.05$ mm (0.75 inch label guide) $\phi 26$ mm (1 inch label guide)

Fan-fold media

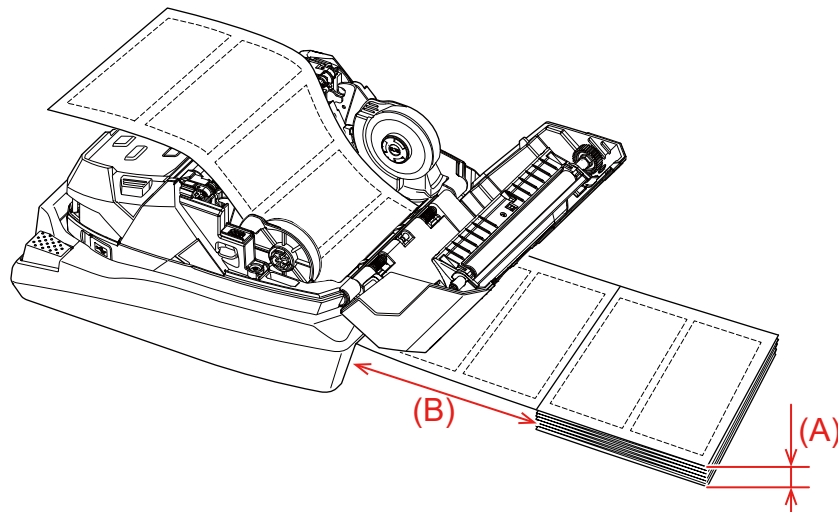

(A) Media height (from the desk): Within 100 mm (approximate)

(B) Distance between the back of the printer and the media: 1 label worth or more (approximate)

AVTO